

Studebaker SERVICE BULLETIN

TUC-348ER

Twin-Traction Differential

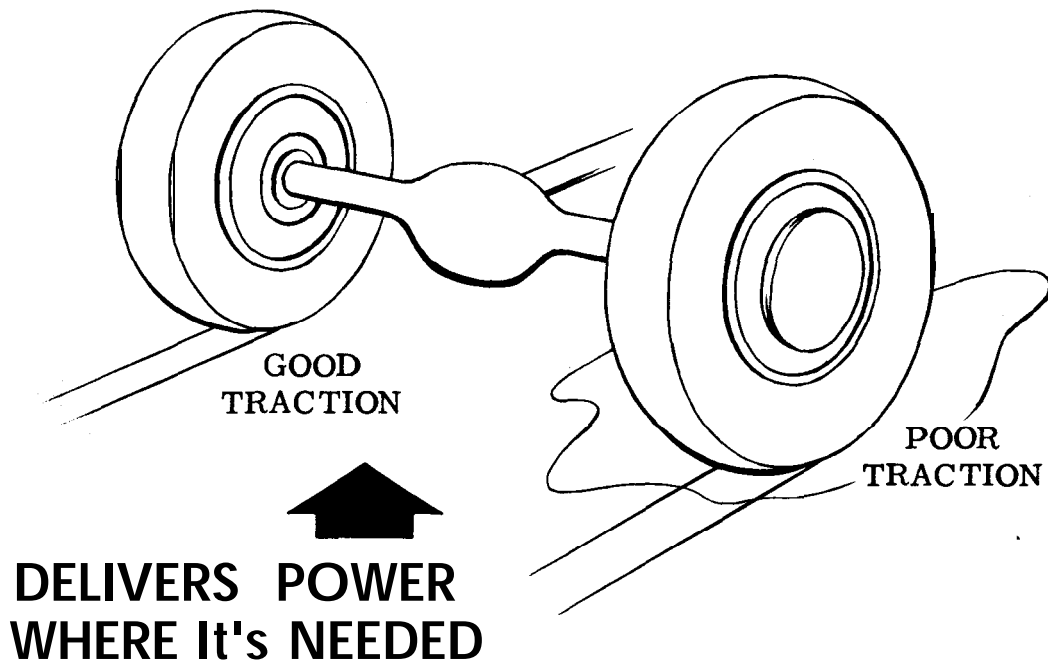

The Twin-Traction differential rear axle now available on 2E5, 2E6, and 2E7 model **trucks** fulfills a long standing need for a differential which prevents a vehicle from becoming immobile when one wheel loses its traction.

Its unique **design** provides several distinctive advantages over the conventional type differential assembly. The main feature of this differential is that it supplies a greater percentage of torque to the wheel with better traction and still furnishes to the wheel with the poorer traction as much torque as it is able to absorb under the circumstances.

In the conventional differential, the wheel easiest to turn receives the power. Therefore, when traction conditions under the rear **wheels** are not the same, the driving force is limited by the wheel with the poorer traction (easiest to turn) even though one wheel is on good traction surface. In the Twin-Traction differen-

tial, power is provided also to the wheel on better traction surface and in this way the driving force gets the advantage of the better traction surface.

The Twin-Traction differential, unlike the full locking type differential, does not permit shock loads or full engine torque to be transmitted to one axle shaft. It provides power to both rear wheels and maintains the differential action that is necessary when the vehicle is turning a corner to permit the outer wheel to turn faster than the inner wheel.

The Twin-Traction differential provides additional vehicle safety and stability during high-speed driving. It prevents wheel spinning and sudden shock loads **due** to wheel bounce over rough roads or non-uniform road conditions such as ice or snow spots, wet and dry pavement, sand and gravel, and one wheel running off the pavement.

with a conventional differential, when a rear wheel is thrown into the air by a bump and road contact is broken, the wheel spins and rapidly gains momentum. As it returns into contact with the road, the sudden shock of contact causes the vehicle to swerve. With the Twin-Traction differential, the wheel hitting the bump cannot spin and gain momentum; consequently, sudden wheel stoppage to cause swerving is not present. This is also true when the wheel hits a patch of ice, snow, or wet pavement; it does not spin and thereby prevents swerving of the vehicle when the wheel returns to the dry pavement. In a situation where one wheel drops off the pavement onto a soft shoulder, the wheel on the pavement continues to drive and the wheel on the shoulder does not spin. Here again swerving is prevented when the wheel comes back on the pavement.

The differential assembly consists of two case halves (1 and 7, Fig. 1), two cross pins (5), differential pinions (4), bevel side gears (3), clutch rings (2), and axle shaft thrust block (6).

The cross pins are made with a movable joint at the center to permit each one to move independently while in continuous engagement. The pin ends are machined in the form of a V (see Fig. 2) and a similar V is machined in each

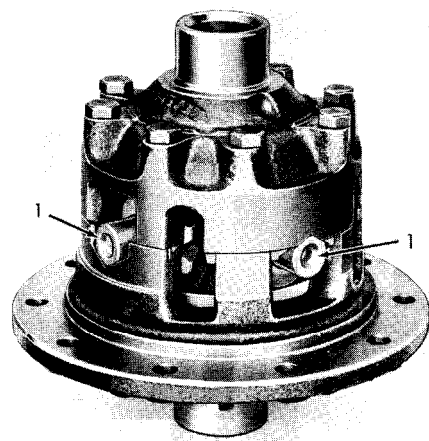

Fig. 6.2
I. CROSS PINS

case half to provide a ramped cam surface. The clutch ring is fitted over each bevel side gear and mates with a cone surface machined in each half of the differential case.

As the vehicle is put in motion, the driving force moves the cross pins (2, Fig. 3) up the ramp or the cam surface (1), applying a load to the clutch rings (4) and restricts turning of the differential, through the friction of the clutch ring on its mating surface (5) in the differential case.

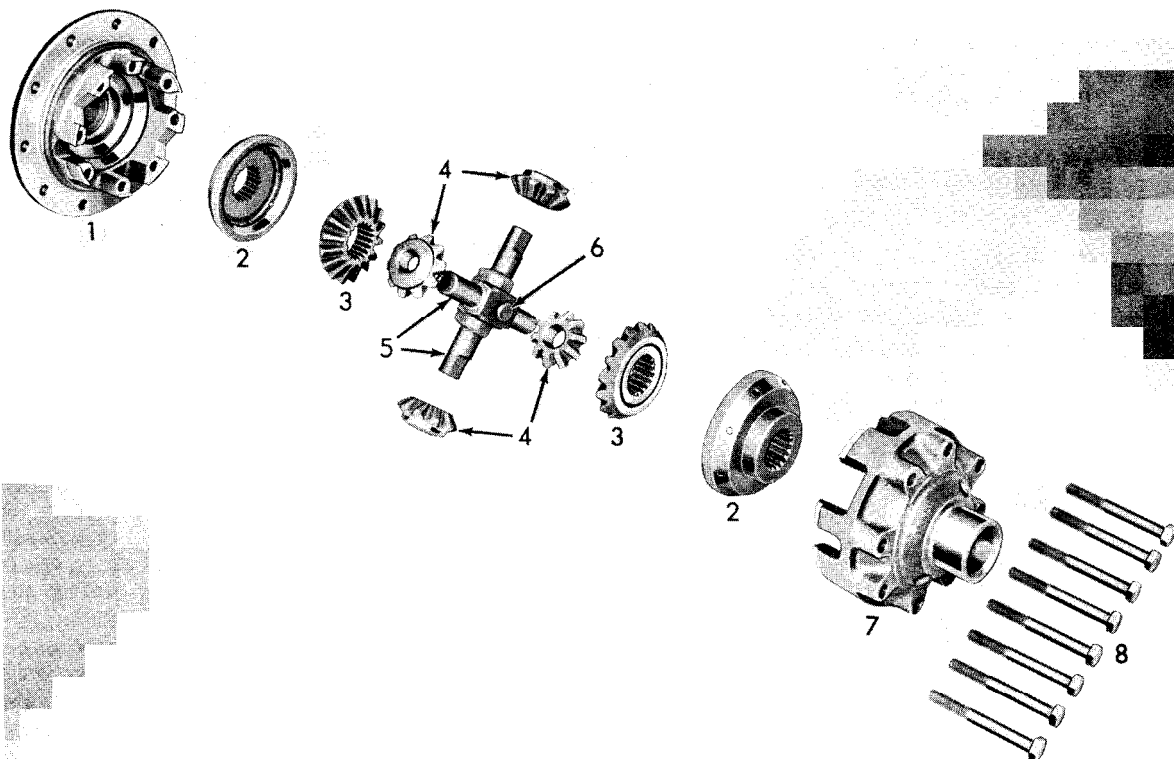

Fig. 1

1. CASE HALF
2. CLUTCH RINGS
3. BEVEL SIDE GEARS

4. DIFFERENTIAL PINIONS
5. CROSS PINS
6. THRUST BLOCK

7. CASE HALF
8. CASE SCREWS

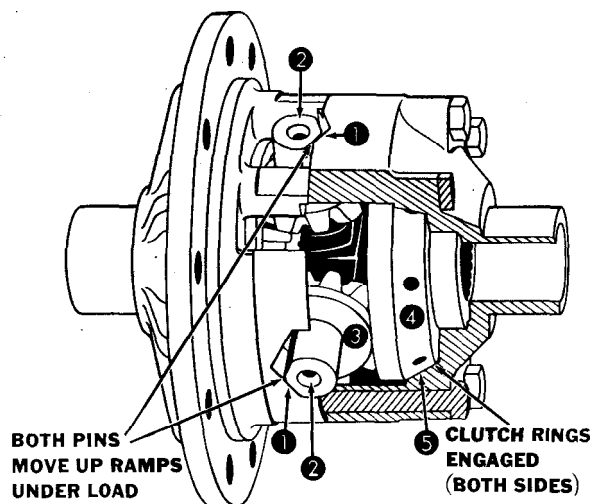

FIG. 3

1. RAMP SURFACE
2. CROSS PINS

3. DIFFERENTIAL PINIONS
4. CLUTCH RINGS

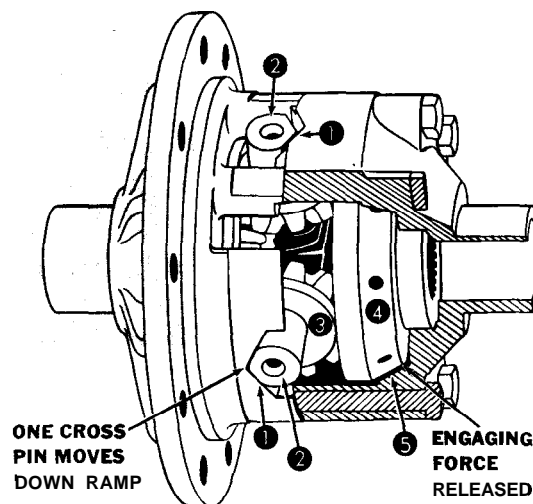

FIG. 4

5. CLUTCH RING MATING SURFACE

This provides a torque ratio between the axle shafts which is based on the amount of friction in the differential and the amount of load that is being applied to the differential.

When turning a corner, this process is in effect partially reversed. The differential gears become a planetary gear set, with the gear on the outside wheel the fixed gear of the planetary. The outer gear of the planetary overruns as the outside wheel has a further distance to travel. With the outer gear overrunning and the inner gear fixed, the differential pinions (3, Fig. 4) are caused to rotate, but since they are restricted by the fixed gear, they must first move the cross pins (2) back down the cam surface (1) relieving the thrust load of the clutch ring on its mating surface in the differential case. Thus when turning the corner, the differential, for all practical purposes, is similar to a conventional differential and the wheels are free to rotate at different speeds.

The engagement of the clutch rings in the Twin-Traction differential provides many features that are not common in other types of locking differentials. On straight driving, the clutch rings are engaged and prevent momentary spinning of the wheels when leaving the road or when encountering poor traction. In turning the corner, the load is relieved from the clutch surfaces so that wear is reduced to a minimum.

Servicing Twin-Traction Differential

The Twin-Traction differential is entirely new in design and certain characteristics must be taken into consideration. Under average driving conditions such as straight ahead,

reverse, extreme right and left turns, the operation will be the same as with the standard differential. However, a little more backlash may be noticed due to the lateral movement of the differential cross pins. In addition, a slight chatter may occur under surge torque with one wheel on a slippery surface. **These conditions are considered normal.**

Should difficulty occur requiring the removal and servicing of the unit, the differential must be replaced as an assembly. Individual parts are not available. For service, the assembly can be ordered through your parts depot as Part No. 1687190 for the 4.09 and 4.27 ratios, and Part No. 1687191 for the 3.73 ratio. It will be furnished less ring gear and side bearings. The 2E Series Twin-Traction axle cannot be used in prior production models.

Service instructions for the removal and installation of the differential case assembly and adjustments of the ring gear and pinion are the same as those described on pages 5 through 8 of the Rear Axle Section of the 2E Series Trucks Shop Manual.

At the time of production, the rear axle is filled with an Elco 28 Hypoid type lubricant. Should it be necessary to add or change the lubricant, use only S.A.E. No. 96 hypoid type lubricant with a sulphur-chlorine-lead base.

CAUTION -- Do not attempt to spin a rear wheel under power with a Jack under only one side; both wheels must be clear of the ground. If one wheel remains in contact with the ground, there is a possibility that when spinning the other wheel, friction on the differential clutch rings may set the vehicle in motion.

STUDEBAKER TRANSTAR TRUCK SERVICE TOPICS

V8 ENGINE

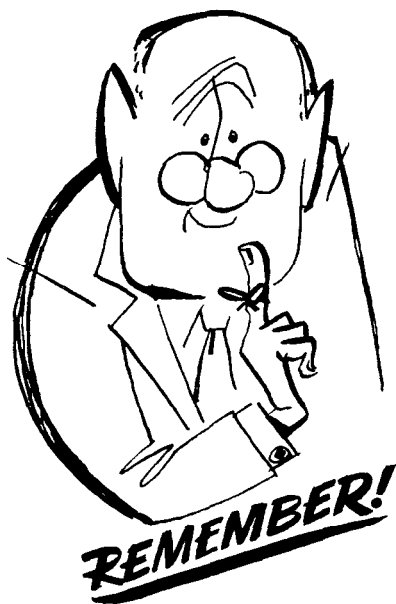

GOOD SERVICE Doesn't Cost --
IT PAYS!

Many a truck **jockey** fancies himself to be a budding genius when it comes to tuning up the engine. Notions regarding valve adjustment, ignition timing, carburetor settings to give more power, are a dime a dozen.

The really smart cooky will learn what the factory specs are and latch onto them as **if** they were his own brain child. For this smart Joe we are listing the tune-up dope for ready reference. It's a good idea to carry it with you.

Spark plug gap .035"

Set ignition exactly on **mark**

Ignition point gap minimum .013"

Cam dwell 28-34°

Cylinder head capscrew torque
60 \pm 5 lbs.

Valve tappet clearance .026"

Engine idle speed 550-600 RPM

Spark **plug**. Tighten to 25-30
lb. rt. torque.

Here are some Do's and Dont's that should be a part of any engine tune-up. If you know them all, good. If not, it will pay you to rake them a part of the program because they are often the **difference** between a slick running engine and one that doesn't run so good.

D O

If you have the spark plugs out and intend to reuse them, always file the end of the center electrode and the inner side of the ground electrode until they are bright and clean.

Always use new gaskets on spark plugs.

Be sure gasket surface on cylinder head is clean.

Tighten spark plugs to recommended torque so that heat will be transferred to cooling system.

When installing ignition points be sure of the gap. Use a **Clean** feeler gage. Set at not less than .013" or more than .015".

Use a spring scale to set the ignition point contact arm spring to 19-24 oz. Properly adjusted spring tension prolongs point **life** and aids in preventing high speed **miss**.

When setting the ignition timing, always disconnect the spark modifier and then set timing exactly on the mark.

Be sure the manual choke works freely. The **choke** valve should be wide open with the knob pushed in.

D O N ' T

Don't forget to check the heat riser valve. This gadget, when not working properly, can really **affect** gas mileage.

Don't forget to check the carburetor throttle for **full** opening by the accelerator pedal after a cylinder head has been removed.

Don't tighten the valve cover retaining nuts too tight. The cover can be distorted causing a permanent oil leak. Just snug them up.

Don't forget to clean the fuel pump bowl.

Don't wait for any specified mileage to clean the air filter. After each run take the cover off and reel the amount of sediment in the bottom of the cleaner. If you get a gob of dirt on your ringer, clean the air cleaner out right then.

Don't monkey with the carburetor idling mixture adjusting screws unless you have tachometer or vacuum gage to tell you when the best mixture is reached.

General Service Department
Studebaker Division
STUDEBAKER-PACKARD CORPORATION
South Bend 27, Indiana