

---

---

**REPORT No. 262**

---

**FRICION OF AVIATION ENGINES**

**By S. W. SPARROW and M. A. THORNE**  
**Bureau of Standards**



# REPORT No. 262

## FRICITION OF AVIATION ENGINES

By S. W. SPARROW and M. A. THORNE

### SUMMARY

The first portion of this report discusses measurements of friction made in the altitude laboratory of the Bureau of Standards between 1920 and 1926 under research authorization of the National Advisory Committee for Aeronautics. These are discussed with reference to the influence of speed, barometric pressure, jacket-water temperature, and throttle opening upon the friction of aviation engines. It is concluded that: (1) Changes in friction due to changes in the temperature of the air entering the engine are negligible. (2) Changes in friction which result from changes in atmospheric pressure are due primarily to changes in pumping loss. An approximate figure for the engines mentioned in this report is that the friction mean effective pressure decreases about one-tenth of a pound per square inch for each decrease of 1 centimeter of mercury in the barometric pressure. (3) The increase in friction resulting from a decrease in throttle opening is due to the change in pumping loss. For the engines mentioned in this report, the change in friction mean effective pressure which accompanies a change in manifold suction of 1 inch (2.54 centimeters) of mercury ranges from 0.20 pound per square inch obtained at an engine speed of 1,200 revolutions per minute to 0.39 at 1,800 revolutions per minute. (4) For the range of speeds covered in this report, namely, from 1,000 to 2,200 revolutions per minute, the friction mean effective pressure increases with speed, but ordinarily the percentage increase is less than the corresponding percentage increase in speed. At low engine speeds the friction mean effective pressure changes much less with change in speed and in some instances remains practically constant. (5) Friction depends upon the viscosity of the oil upon the cylinder walls, which in turn depends upon the temperature of the jacket water. (6) While theoretical considerations would lead one to expect an increase in friction with increase in compression ratio the evidence at hand indicates that this effect is slight.

The second section of the report deals with measurements of the friction of a group of pistons differing from each other in a single respect, such as length, clearance, area of thrust face, location of thrust face, etc. Results obtained with each type of piston are discussed and attention is directed particularly to the fact that the friction chargeable to piston rings depends upon piston design as well as upon ring design. This is attributed to the effect of the rings upon the thickness and distribution of the oil film which in turn affects the friction of the piston to an extent which depends upon its design.

### INTRODUCTION

In connection with tests of aviation engines in the altitude laboratory of the Bureau of Standards considerable attention has been paid to measurements of engine friction. Part I of this report presents and discusses some of these measurements with a view to showing the influence of changes in speed, barometric pressure, jacket-water temperature, and throttle opening upon the friction of aviation engines.

Part II discusses experiments made to obtain information on the influence which certain features of piston design have upon friction. For these experiments several groups of pistons originally of the same dimensions within manufacturing tolerances were modified with respect to length, clearance, area of thrust face, location of thrust face, etc. The friction of pistons thus modified was compared with the friction of the unmodified pistons, under several conditions of engine operation.

Both parts of the report are admittedly incomplete, presenting results with comments as to their probable significance rather than with explanations based upon definite knowledge. Nevertheless it is believed that the information will prove useful as indicating the effect of a change in altitude upon engine friction and suggesting how such friction may be affected by various factors.

## PART I

### FRICION HORSEPOWER, DEFINITION AND METHOD OF MEASUREMENT

For the purpose of this paper friction horsepower is defined as the difference between indicated horsepower<sup>1</sup> and brake horsepower. As thus defined it includes the power expended in drawing in and exhausting the charge, known as the pumping loss, and in driving the auxiliaries such as pump, magneto, etc., as well as the power expended in what can strictly be termed engine friction. Measurements of friction were made in the usual manner, namely by driving the engine by the dynamometer with ignition and fuel turned off but with oil and water temperatures maintained as nearly as possible at their normal operating values.

Numerous objections may be raised to this method of measuring friction horsepower. For example the pumping loss, the power expended in drawing in and expelling the charge, under such conditions is slightly lower than when the engine is operating under its own power as the pressure at the beginning of the exhaust stroke is approximately atmospheric when making friction measurements whereas it may be 20 or 30 pounds per square inch above atmospheric when the engine is operating under its own power. Moreover the side thrust of the piston obviously is greater under explosion pressures than under compression pressures. This, however, is of importance only to the extent to which it affects the thickness of the oil film, as fluid friction is practically independent of pressure<sup>2</sup> so long as the film thickness remains constant. Of course, if for any portion of the stroke there is metal to metal contact the friction for that portion will increase with increase in pressure. The influences mentioned thus far tend to make the friction under load greater than when the engine is being driven by the dynamometer. One would expect the temperature of the oil film upon the cylinder wall to be slightly higher than the jacket-water temperature and that this difference would be greater when the engine is operating under its own power. This effect in its influence upon friction is in the opposite direction to, and tends to compensate for, those that have been mentioned. Presumably the magnitude of these influences is small, as available evidence confirms the belief that friction as measured by the method described is approximately equal to the friction of the engine when it is operating under its own power. Ricardo, in Great Britain, reached the same conclusion after a painstaking study of the subject in which several methods of measuring friction were employed. (See bibliography.) Records of engine tests in the altitude laboratory furnish many examples where the change of indicated horsepower (brake horsepower + friction horsepower) agrees with what would be expected from theoretical considerations to an extent very difficult to explain were the friction measurements appreciably in error.

---

<sup>1</sup> Indicated horsepower is understood to be the net work done on the piston during the compression and expansion strokes. While it may be obtained from an indicator card, sufficiently accurate indicator cards are not generally available in connection with high-speed internal-combustion engine operation, and it is normally figured back from measurements of the brake horsepower and the various losses (the pumping loss, power to drive auxiliaries, etc.).

<sup>2</sup> This is not strictly true, as Hersey has shown that viscosity changes slightly with pressure. See third report on "Viscosity of Lubricating Oils at High Pressure," *Mechanical Engineering*, Vol. 45, May, 1923, p. 315.

## FRICTION MEAN EFFECTIVE PRESSURE, DEFINITION

In most of the curves in this report the quantity plotted is friction mean effective pressure (F. M. E. P.). This may be defined as the pressure per unit area of piston head which, if applied and maintained constant through each working stroke, would produce an amount of power equivalent to the friction horsepower. Friction does not manifest itself as a pressure nor does it necessarily or probably remain constant, and from this standpoint the term F. M. E. P. has little excuse for existence. The reason for its use in preference to horsepower will be evident from an examination of the following general equation:

$$\text{Mean effective pressure} = \frac{\text{horsepower} \times 792,000}{\text{R. P. M.} \times \text{piston displacement}}$$

where mean effective pressure is given in pounds per square inch and piston displacement in cubic inches. It will be observed that the mean effective pressure is proportional to the horsepower of an engine of unit piston displacement operated at unit speed and hence forms a convenient basis for comparing the friction of engines which differ as to size and speed.

## ATMOSPHERIC TEMPERATURE AND FRICTION

There appears to be no reason to expect that seasonal or climate changes in the temperature of the air entering the engine will be of sufficient magnitude to produce a measurable change of friction horsepower. Moreover, tests have shown no indication of such an effect. Results have been plotted, therefore, against barometric pressure rather than against air density, as the effect upon friction of a change of air density would depend upon whether the change was due to a change in pressure or temperature.

## ATMOSPHERIC PRESSURE AND FRICTION

Figures 1 to 7 show relations between F. M. E. P. and barometric pressure as determined from tests of several engines operating at various speeds and jacket-water temperatures. Figures 1 to 5 were derived from groups of curves such as are shown in Figure 8. Such groups were obtained from tests under conditions corresponding to sea level and altitudes of 5,000, 10,000, 15,000, 20,000, and 25,000 feet. The engine was operated at several speeds and at several jacket-water temperatures, and because of the consistency and large number of the measurements it is believed that the results merit considerable confidence. Figures 6 and 7 are based upon a much smaller number of measurements and for that reason are somewhat less trustworthy.

It is well at this point to emphasize the statement made previously to the effect that the information presented in these curves was obtained at intervals covering a long period of time and with engines differing in piston design and many other respects. It is entirely possible that oils of different viscosities were used with the different engines. For this reason one should use considerable caution in comparing the friction of one engine with the friction of another or the friction at one compression ratio with the friction at another compression ratio. Fortunately this limitation is not likely to be of major importance in comparing engines from the standpoint of changes in friction with change of barometric pressure, which is one of the objects of this paper. This results from the fact that the change of friction with change of barometric pressure is primarily due to a change in pumping loss and should not be materially affected by piston design or oil viscosity provided these are such as to insure an adequate oil seal between the piston and cylinder wall.

## WHY ATMOSPHERIC PRESSURE AFFECTS PUMPING LOSS

There is no intention of discussing fully the factors which affect the pumping loss and the reasons why this loss should be proportional to the barometric pressure. In this report the intention is merely to point out that measurements of friction indicate that such relation does exist and to suggest why it would reasonably be expected.

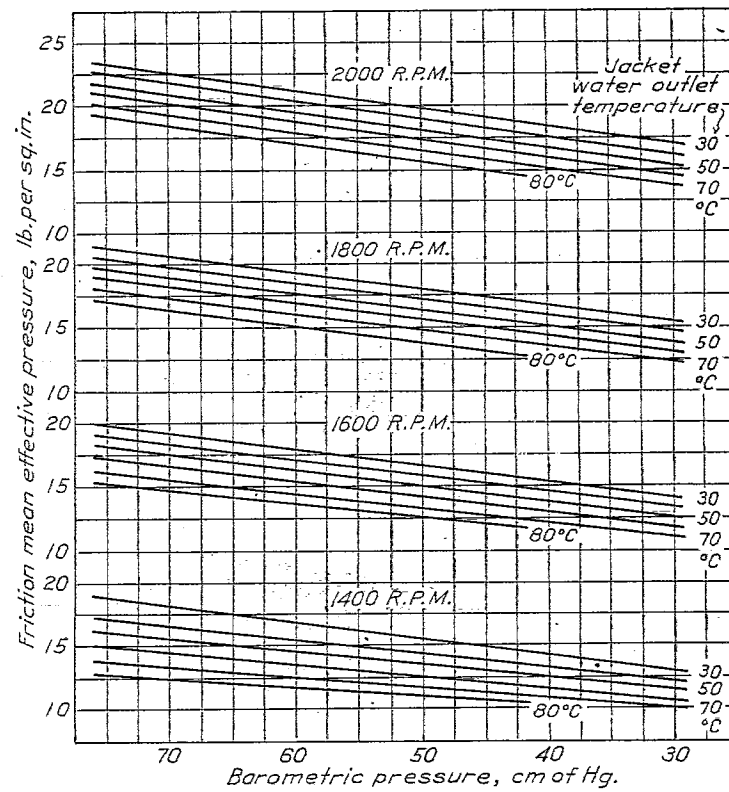

FIG. 1.—Compression ratio, 6.5. Engine A, 8 cylinders

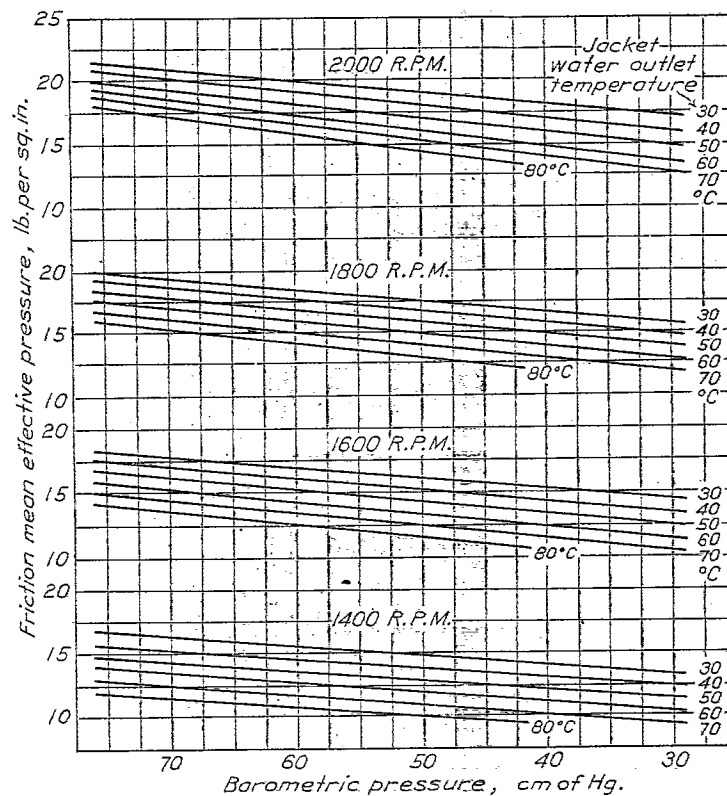

FIG. 2.—Compression ratio, 5.4; bore, 5.51 inches; stroke, 5.91 inches

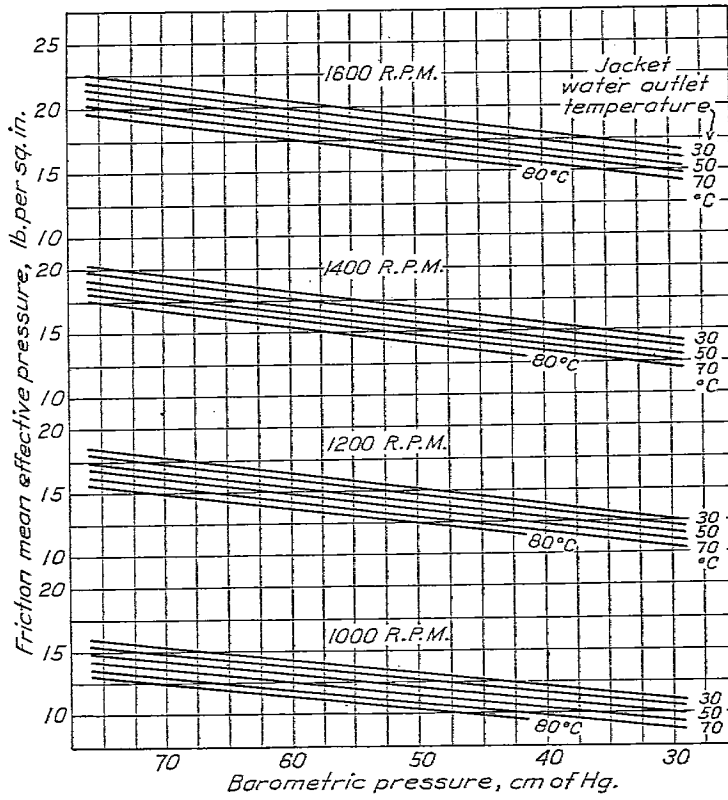

FIG. 3.—Compression ratio, 6.5. Engine B, 6 cylinders

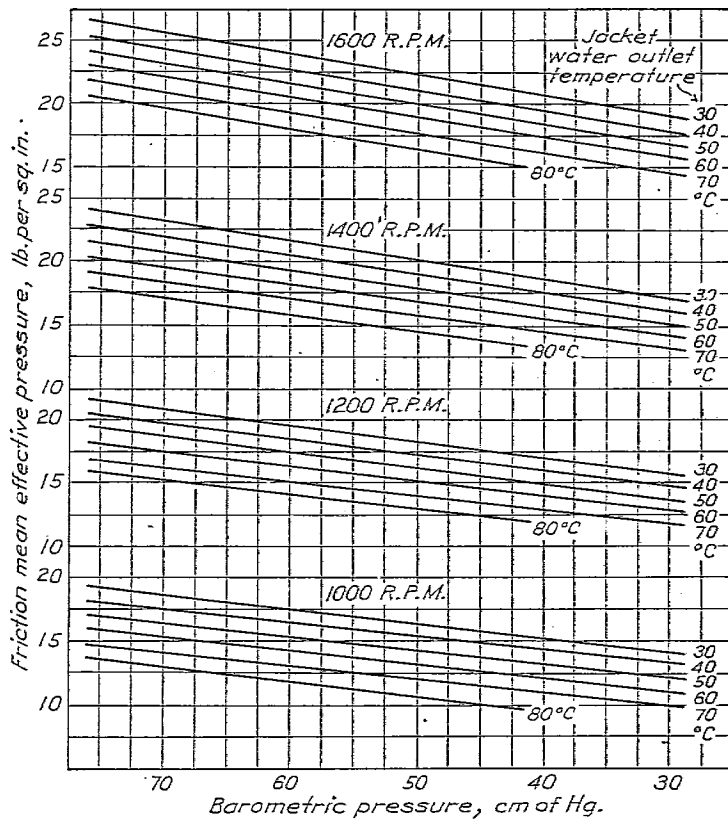

FIG. 4.—Compression ratio 5.5; bore, 6.62 inches; stroke, 7.5 inches

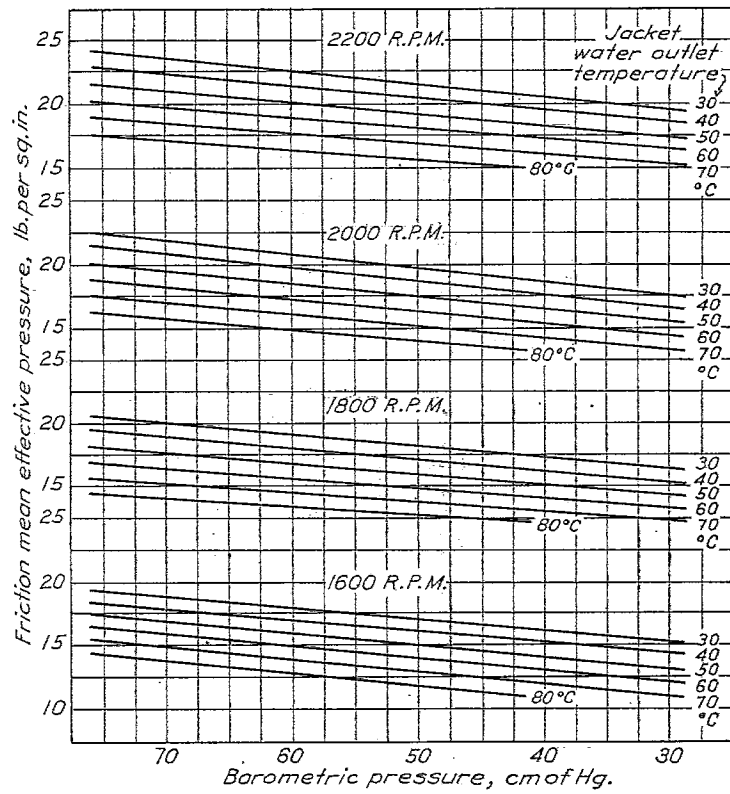

Fig. 5.—Compression ratio, 5.3. Engine C: 12 cylinders; bore, 4.5 inches; stroke, 6 inches

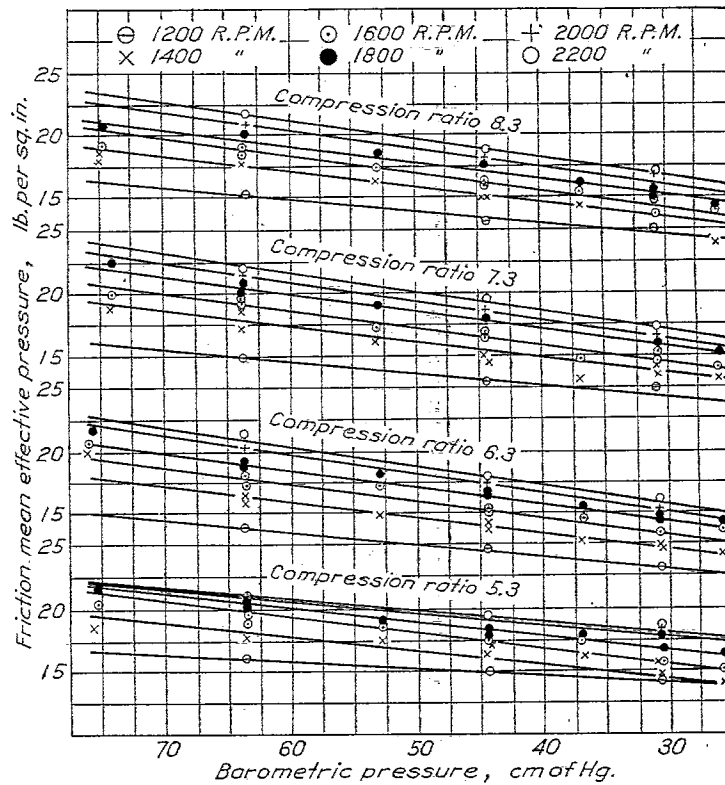
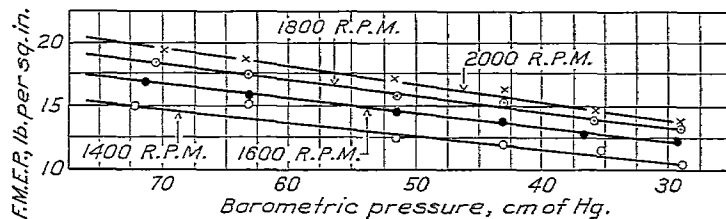
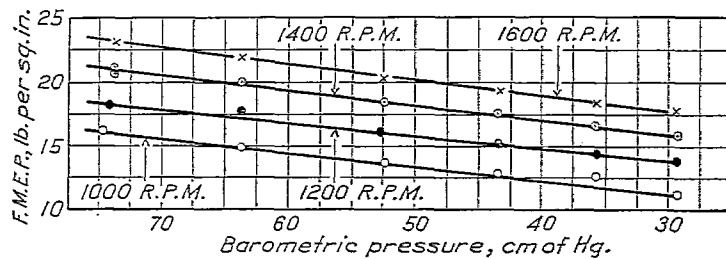

Fig. 6.—Engine D: 8 cylinders; bore, 4.72 inches; stroke, 5.12 inches



Engine G: 12 cylinders; bore, 5 inches; stroke, 5.25 inches; compression ratio, 6.5



Engine E: 6 cylinders; bore, 6.5 inches; stroke, 7.09 inches; compression ratio, 5.9

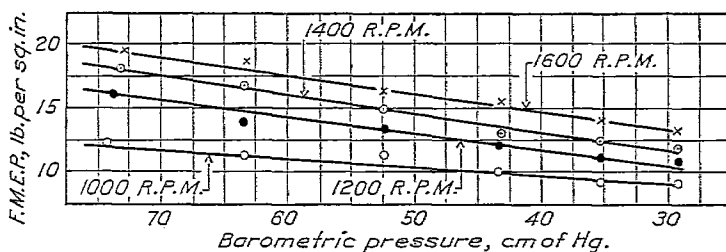

Engine F: 6 cylinders; bore, 5.9 inches; stroke, 7.09 inches; compression ratio, 6.7

FIG. 7 (a, b, c)

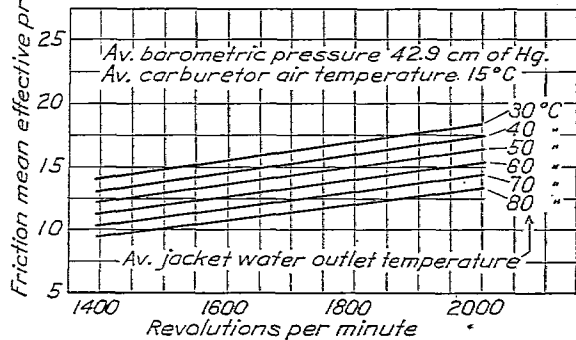
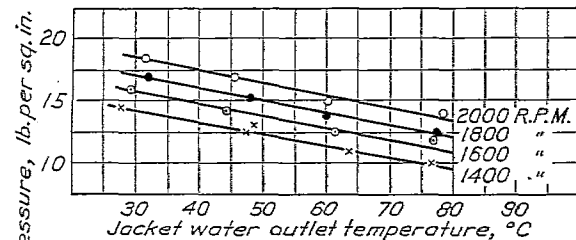

FIG. 8.—Engine A: 8 cylinders; bore, 5.51 inches; stroke, 5.91 inches; compression ratio, 6.5

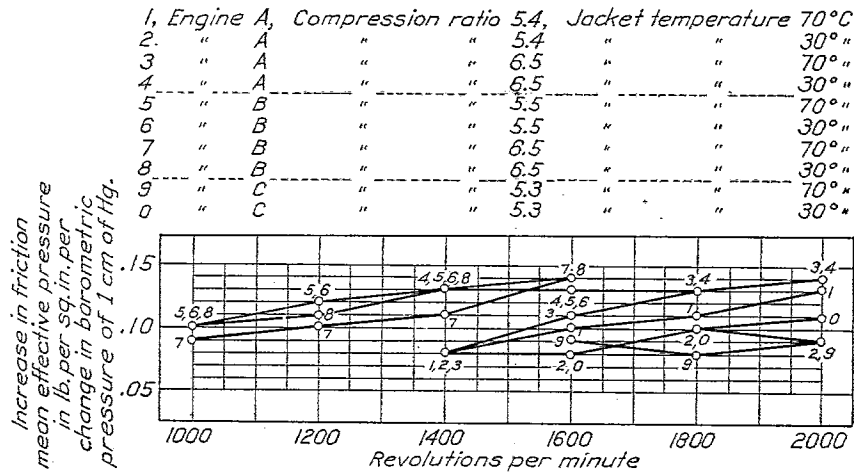

FIG. 9.—Change in friction with change in barometric pressure

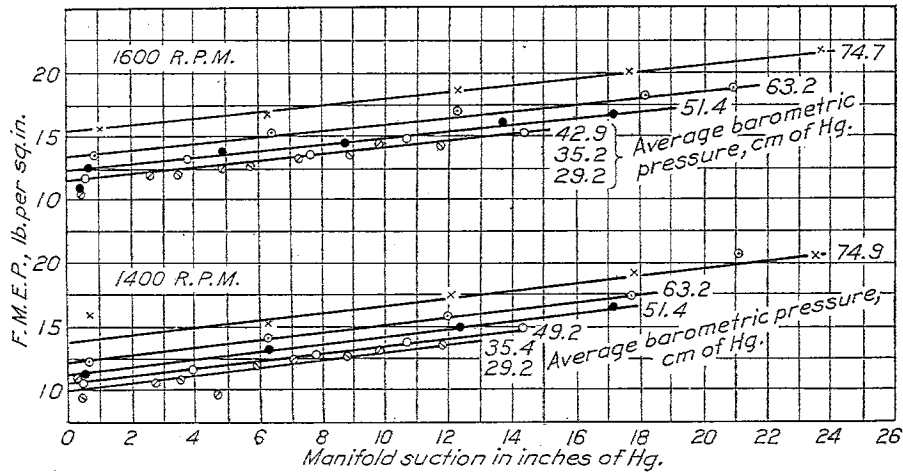

FIG. 10.—Engine A: 8 cylinders; bore, 5.51 inches; stroke, 5.91 inches; compression ratio, 5.4; change in F. M. E. P. per change in manifold suction of 1 centimeter (2.54 inches) Hg, 0.26 lb./sq. in. at 1,600 R. P. M., 0.29 lb./sq. in. at 1,400 R. P. M.

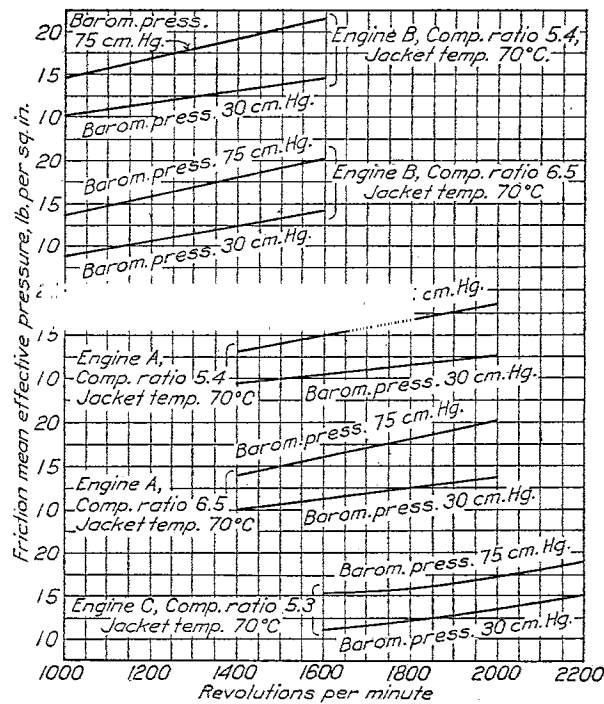

FIG. 11.—Friction versus engine speed

Tests in the altitude laboratory have shown that volumetric efficiency is not affected by changes in barometric pressure. The term volumetric efficiency as here used may be defined as the ratio between the volume of charge received per cycle measured at the temperature and pressure existing at the entrance to the carburetor and the piston displacement. In other words the volume of charge entering the engine per cycle when the barometric pressure is 38 centimeters of mercury is the same as the volume when the pressure is 76 centimeters of mercury. The weight of air entering the engine per cycle at the lower pressure is, of course, only one-half as great. Volumetric efficiency is determined by the conditions governing flow into the cylinder on the intake stroke and out from the cylinder on the exhaust stroke. That the rate of flow is not affected by changes of barometric pressure is indicated by the fact that the volumetric efficiency remains constant. If for any portion of the cycle the volume rate of flow is to be the same for two different barometric pressures, the relation between the pressure differences producing flow in the two cases must be such as to make the heads producing flow the same when measured at the temperature and pressure of the fluid flowing. To accomplish this the actual pressure differences must be directly proportional to the barometric pressure. Since these pressure differences govern the pumping losses, such losses therefore should vary directly as the barometric pressure.

In Report No. 190 of the National Advisory Committee for Aeronautics, which is entitled "Correcting Horsepower Measurements to a Standard Temperature" it is pointed out that the volumetric efficiency changes with change of atmospheric temperature. As has been stated, experiments indicate that changes in atmospheric temperature have a negligible influence upon friction. These facts are not inconsistent with the discussion in the previous paragraph since the change in volumetric efficiency with change in atmospheric temperature is due primarily to a change in the volume rate of flow with a given pressure difference which does not change appreciably with change in atmospheric temperature rather than to changes in such pressure differences and consequently in the pumping losses.

#### ENGINE SPECIFICATIONS

Before discussing the actual changes in friction with change in barometric pressure shown in Figures 1 to 7 it will be well to furnish sufficient information concerning the engines to serve as a basis for their identification. Table I furnishes such information. It will be noted that tests were made with two compression ratios with engines A and B and with four compression ratios with engine D. In each case the difference in compression ratio was obtained by changing pistons.

#### CHANGE IN FRICTION PER UNIT CHANGE IN BAROMETRIC PRESSURE

Table II was derived from Figures 1 to 7 and shows changes in F. M. E. P. per unit change of barometric pressure. As a matter of interest, mean piston speed has been tabulated in addition to revolutions per minute. While the table shows a rather wide range of values to have been obtained, it at least gives an idea as to the probable accuracy with which the change of friction with altitude can be predicted and may serve as a basis for such predictions.

Figure 9 shows data from the engines which have been tested most completely. In this figure the points are taken from the plotted curves and not from original data. Elsewhere in the report the conventional practice of using points only to indicate original data is followed. As would be expected, there is a tendency for the values to increase with speed. Since these are values of actual rather than percentage change, the increase with speed merely indicates that pumping losses are greater for high speeds than for low. From Figure 9 it would appear that the F. M. E. P. decreases about one-tenth of a pound per square inch for a decrease in barometric pressure of 1 centimeter of mercury.

#### THROTTLE OPENING AND FRICTION

When an engine is operated with partly closed throttle the friction is higher than at full throttle because of the higher pumping loss. Figure 10 shows a typical group of measurements made in connection with the altitude laboratory test of engine A. In such tests the friction

at various jacket water temperatures is measured only at full throttle. In order to obtain the friction at part throttle, there is added to the appropriate full throttle value an amount determined by means of (1) such information as is shown in Figure 10 and (2) knowledge as to the difference between the manifold suction at full and part throttle.

For the engines tested thus far it has been found that friction varies almost linearly with manifold suction and that the magnitude of this variation is approximately the same for various altitudes. As is shown in Figure 10, with engine A and a compression ratio of 5.4, a change in manifold suction of 1 inch (2.54 centimeters) of mercury changes the F. M. E. P. at 1,600 R. P. M. by about 0.26 pound per square inch, whereas at 1,400 R. P. M. the change is 0.29 pound. The same values were obtained in tests of this engine with the 6.5 compression ratio. With engine B and a compression ratio of 5.5, values of 0.20 and 0.24 were obtained for speeds of 1,200 and 1,000 R. P. M., respectively, while for a compression ratio of 6.5 a value of 0.19 was obtained at 1,200 R. P. M. and 0.18 at 1,000 R. P. M. For engine C a value of 0.39 was obtained for a speed of 1,800 R. P. M. and 0.38 for 1,600 R. P. M.

These values have been quoted as being of interest rather than as being of major importance in a general analysis of engine friction. This arises from the fact that the pumping losses are dependent upon the pressures and the distance through which they act whereas the manifold suction depends upon the *time* during which these pressures act. Moreover the manifold pressure is dependent upon the volume of the intake system, the number of cylinders which draw from it, etc., and its relation to the pressures in the cylinder depends upon valve areas, valve timing, piston speed, etc.

#### ENGINE SPEED AND FRICTION

Figure 11 shows values of F. M. E. P. over the normal operating range of speeds of engines A, B, and C. It will be noted that in this range the F. M. E. P. increases with speed and that in most instances the percentage increase is less than the corresponding percentage increase in speed. At very low speeds the F. M. E. P. changes to a much less extent with change of speed and in some instances remains almost constant over a considerable range. If the F. M. E. P. increases with speed then the friction horsepower will increase more than in proportion to the speed. This is chiefly responsible for the decrease in mechanical efficiency that ordinarily results from an increase in speed.

#### JACKET-WATER TEMPERATURE AND FRICTION

The influence of jacket-water temperature upon friction is clearly evidenced in Figures 1 to 5. The reason for this influence is, of course, that the temperature of the jacket water governs the temperature of the oil film upon the cylinder walls and consequently its viscosity. Thus far in the work with aviation engines the temperature of the circulating oil has not appeared to affect friction materially, the influence of the temperature of the jacket water being dominant. There are indications, however, that the temperature of the circulating oil does have an appreciable effect upon the friction of certain motor car engines. It is possible that in these engines the friction of main and connecting rod bearings or the power required to drive the oil pump may constitute a greater percentage of the total engine friction than is usually the case.

The oil used in the tests of engines A and B had the following viscosities:

Temperature (°C.)	Viscosity (seconds), Saybolt Universal
30	6,700
40	2,415
50	1,105
60	570
70	327
80	191
90	128
100	81

Engines must operate, during the starting period at least, with jacket-water temperatures below normal. To prevent abnormally high-friction losses during such periods, it is desirable that the change in the viscosity of an oil with change in temperature be small. This is desirable also for the reason that an oil should be of high enough viscosity to maintain a lubricating film at maximum pressures and temperatures and yet of low enough viscosity to flow freely under cold starting conditions.

These curves (figs. 1 to 5) emphasize the importance of reducing to a minimum the amount of engine operation at jacket-water temperatures *other than normal*. If the normal operating temperature is high, then operation at lower jacket temperatures will result in unduly high friction losses and consequently lower brake thermal efficiencies. On the other hand, if the normal operating temperature is low, then operation at high jacket temperatures may be dangerous, as the viscosity of the oil may not be adequate to prevent metal-to-metal contact.

One should not conclude from these curves, however, that friction losses are necessarily high for engines which normally operate at low jacket-water temperatures. Such engines ordinarily permit the use of an oil of comparatively low viscosity and hence have friction losses no greater than those of engines whose normal operating temperature is high. Friction is therefore ultimately more dependent upon the *range* of operating temperatures than upon the actual temperatures.

#### COMPRESSION RATIO AND FRICTION

In tests of engine A it was found that with a jacket-water temperature of 80° C., practically the same friction was obtained with compression ratios of 5.4 and 6.5, whereas with a jacket-water temperature of 30° C. the friction was materially higher for the lower compression ratio. With engine B, conditions were somewhat reversed, the friction with a compression ratio of 6.5 being higher at all jacket-water temperatures than with a compression ratio of 5.5. Although, for reasons already given, the results obtained from engine D are somewhat less dependable, it is of interest to note that the highest values of friction were obtained with the 5.3 ratio and the lowest with the 6.3, the values for ratios of 7.3 and 8.3 being between these two. In tests with a single-cylinder engine having a bore of 5 inches and a stroke of 7 inches no changes in friction with change in compression ratio were noted over a range of ratios extending from 5.4 to 14.

Hence while there are theoretical grounds for expecting a slight increase in friction with increase in compression ratio, from the evidence at hand it appears that the magnitude of this effect is ordinarily so small as to be masked by accidental differences in the pistons used to obtain the different compression ratios.

#### CONCLUSIONS

(1) Changes in friction due to changes in the temperature of the air entering the engine are negligible.

(2) Changes in friction which result from changes in atmospheric pressure are due primarily to changes in pumping loss. There is a wide difference between engines in the extent to which the friction changes with a given change of barometric pressure. An approximate figure for the engines mentioned in this report is that the F. M. E. P. decreased about one-tenth of a pound per square inch for each decrease of 1 centimeter of mercury in the barometric pressure.

(3) The increase in friction resulting from a decrease in throttle opening is also the effect of a change in pumping loss. For the engines mentioned in this report changes in throttle opening cause the mean effective pressure to vary in an almost linear relation to manifold suction. Values are quoted which show that for these engines the change in F. M. E. P. which accompanies a change in manifold suction of 1 inch (2.54 centimeters) of mercury ranges from 0.20 pound per square inch, obtained at an engine speed of 1,200 R. P. M., to 0.39 at 1,800 R. P. M.

(4) Nearly all of the data presented in this report were obtained for engine speeds ranging from 1,000 to 2,200 R. P. M. Over this range the F. M. E. P. increases with speed, but ordinarily the percentage increase is less than the corresponding percentage increase in speed. At low engine speeds the F. M. E. P. changes to a much less extent with change in speed, in some instances remaining practically constant over a considerable range.

(5) Friction depends very greatly upon the viscosity of the oil upon the cylinder walls, which in turn depends upon the temperature of the jacket water. It does not follow that the friction of an engine which normally operates at a low jacket-water temperature will necessarily be high, but it is important to take this temperature into consideration when selecting the oil and to reduce to a minimum the amount of operation that takes place at temperatures other than normal.

(6) From theoretical considerations one would expect that friction would increase with increase in compression ratio, but from the evidence at hand this effect appears to be slight.

TABLE I  
SPECIFICATIONS OF ENGINES USED IN FRICTION TESTS

Engine	Bore (in inches)	Stroke (in inches)	Number of cylinders	Compression ratio
A	5.51	5.91	8	6.5
B	6.62	7.50	6	5.4
C	4.50	6.00	12	6.5
D	4.72	5.12	8	5.5
E	6.50	7.09	6	5.3
F	5.90	7.09	6	5.3
G	5.00	5.25	12	6.3
				7.3
				8.3
				5.9
				6.7
				6.5

TABLE II  
CHANGE IN F. M. E. P. FOR CHANGE IN BAROMETRIC PRESSURE OF 1 CENTIMETER Hg

R. P. M. ....	1,200	1,400	1,600	1,800	2,000	2,200	
Mean piston speed .... feet per minute..	1,024	1,195	1,365	1,536	1,707	1,877	
	0.06	0.12	0.13	0.11	0.09	0.09	Engine D, compression ratio, 5.3.
	.10	.13	.14	.14	.16	.16	Engine D, compression ratio, 6.3.
	.10	.13	.14	.14	.15	.15	Engine D, compression ratio, 7.3.
	.10	.13	.14	.13	.15	.15	Engine D, compression ratio, 8.3.
R. P. M. ....		1,000	1,200	1,400	1,600		
Mean piston speed .... feet per minute..		1,182	1,418	1,654	1,891		
		0.07	0.13	0.15	0.14		Engine F.
R. P. M. ....		1,400	1,600	1,800	2,000		
Mean piston speed .... feet per minute..		1,225	1,400	1,575	1,750		
		0.10	0.11	0.12	0.14		Engine G.
R. P. M. ....		1,000	1,200	1,400	1,600		
Mean piston speed .... feet per minute..		1,182	1,418	1,654	1,891		
		0.11	0.10	0.12	0.13		Engine E.

CHANGE IN F. M. E. P. FOR CHANGE IN BAROMETRIC PRESSURE OF 1 CENTIMETER Hg—Continued

R. P. M. Mean piston speed.....feet per minute..	1,400 1,379	1,600 1,576	1,800 1,773	2,000 1,970	
	0.13	0.13	0.13	0.14	Engine A, compression ratio, 6.5; jacket-water temperature, 30° C.
	.11	.12	.13	.14	Engine A, compression ratio, 6.5; jacket-water temperature, 40° C.
	.10	.12	.13	.14	Engine A, compression ratio, 6.5; jacket-water temperature, 50° C.
	.09	.12	.13	.14	Engine A, compression ratio, 6.5; jacket-water temperature, 60° C.
	.08	.11	.13	.14	Engine A, compression ratio, 6.5; jacket-water temperature, 70° C.
	.07	.10	.13	.14	Engine A, compression ratio, 6.5; jacket-water temperature, 80° C.
	.08	.08	.10	.09	Engine A, compression ratio, 5.4; jacket-water temperature, 30° C.
	.07	.09	.10	.10	Engine A, compression ratio, 5.4; jacket-water temperature, 40° C.
	.07	.09	.10	.11	Engine A, compression ratio, 5.4; jacket-water temperature, 50° C.
	.08	.09	.11	.12	Engine A, compression ratio, 5.4; jacket-water temperature, 60° C.
	.08	.10	.11	.13	Engine A, compression ratio, 5.4; jacket-water temperature, 70° C.
	.07	.10	.11	.14	Engine A, compression ratio, 5.4; jacket-water temperature, 80° C.
R. P. M. Mean piston speed.....feet per minute..	1,000 1,250	1,200 1,500	1,400 1,750	1,600 2,000	
	0.10	0.12	0.13	0.13	Engine B, compression ratio, 5.5; jacket-water temperature, 30° C.
	.10	.12	.13	.13	Engine B, compression ratio, 5.5; jacket-water temperature, 40° C.
	.11	.12	.13	.13	Engine B, compression ratio, 5.5; jacket-water temperature, 50° C.
	.11	.12	.13	.13	Engine B, compression ratio, 5.5; jacket-water temperature, 60° C.
	.10	.12	.13	.13	Engine B, compression ratio, 5.5; jacket-water temperature, 70° C.
	.10	.12	.13	.13	Engine B, compression ratio, 5.5; jacket-water temperature, 80° C.
	.10	.11	.13	.14	Engine B, compression ratio, 6.5; jacket-water temperature, 30° C.
	.09	.11	.12	.14	Engine B, compression ratio, 6.5; jacket-water temperature, 40° C.
	.09	.11	.12	.14	Engine B, compression ratio, 6.5; jacket-water temperature, 50° C.
	.09	.10	.12	.14	Engine B, compression ratio, 6.5; jacket-water temperature, 60° C.
	.09	.10	.11	.14	Engine B, compression ratio, 6.5; jacket-water temperature, 70° C.
	.10	.09	.11	.14	Engine B, compression ratio, 6.5; jacket-water temperature, 80° C.
R. P. M. Mean piston speed.....feet per minute..	1,600 1,600	1,800 1,800	2,000 2,000	2,200 2,200	
	0.08	0.10	0.11	0.10	Engine C, jacket-water temperature, 30° C.
	.08	.09	.10	.10	Engine C, jacket-water temperature, 40° C.
	.09	.09	.10	.09	Engine C, jacket-water temperature, 50° C.
	.09	.08	.09	.09	Engine C, jacket-water temperature, 60° C.
	.09	.08	.09	.08	Engine C, jacket-water temperature, 70° C.
	.09	.07	.08	.08	Engine C, jacket-water temperature, 80° C.



PART II  
 FRICTION OF PISTONS  
 GENERAL COMMENT

This section of the report is to present the results of the measurements of friction obtained with the group of pistons shown in Figures 12 to 19. These pistons as originally received were all the same within close manufacturing tolerances. In modifying them as regards length, clearance, area of thrust face, location of thrust face, etc., the sole object sought was the obtaining of information as to the influence of the changes upon piston friction. No attempt was made to obtain piston designs which would be satisfactory from the standpoint of gas tightness, strength, wear, or freedom from noise. In fact, the changes made were usually far greater than would be permissible in service but, being large, the effects of the changes were much less likely to be masked by other influences than would have been the case had the pistons been modified only to the extent which would be feasible in normal operation.

It has not been possible to carry this work far enough to justify definite predictions as to the magnitude of the changes in friction which would result from a given change in piston design. Nevertheless although the information obtained thus far is qualitative and incomplete it is believed to be of sufficient value to warrant its publication at this time.

Measurements of friction were obtained, as is customary, by driving the engine by the dynamometer, with ignition and fuel turned off and with temperatures of oil and water maintained at predetermined values. Friction as thus measured includes not only piston friction but also the friction of main, connecting rod, and piston pin bearings, the power expended in driving the auxiliaries such as water pump, oil pump, magneto, etc., and the pumping loss, which is the term applied to the power utilized in drawing in and expelling the charge.<sup>3</sup> As only pistons were changed in these experiments, any changes found in the total engine friction could reasonably be ascribed to differences between pistons.

The engine used in these experiments was designed for use in a truck and is of the rugged construction essential to such service. It is water-cooled and has a bore of  $4\frac{3}{4}$  inches and a stroke of 6 inches. The cylinders are cast in blocks of two and are bolted to the upper half of the crankcase. This construction permits the cylinders to be removed for the installation of pistons and rings and makes it unnecessary to disturb connecting rod big-end bearings. Changes in the bearings during these tests were therefore limited to the slight increase in clearance which resulted from wear.

For many of the experiments it was considered highly desirable to eliminate the pumping loss or rather to reduce it to a negligible value. This was accomplished by removing the spark plugs and holding the valves open by means of wedges. From the standpoint of reducing pumping losses it would have been simpler to remove the cylinder head, but this would have complicated the problem of maintaining the circulation and hence of controlling the temperature of the jacket water.

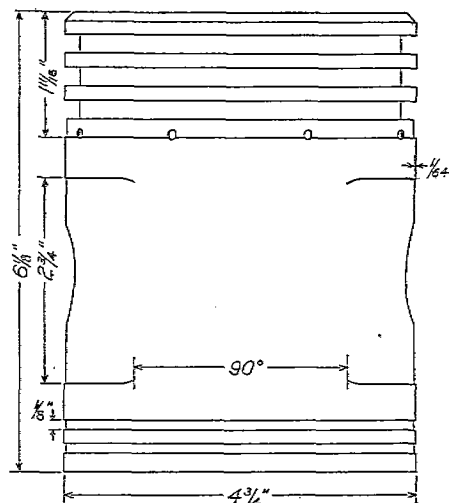

FIG. 12.—Standard piston; total area of piston bearing not in relieved portion, 41 square inches

<sup>3</sup> The slight heat loss to the cylinder walls during the compression stroke is also included in the term "pumping loss."

In this engine, as in all others which have been tested at the Bureau of Standards, the condition of operation which has the chief effect upon piston friction is the temperature of the jacket water, the reason being that this governs the viscosity of the oil upon the cylinder walls. The friction of this particular engine was appreciably influenced also by the temperature of the circulating oil, which has not been the case with most of the engines—of the aviation type, at least—tested at the bureau. Probably the viscosity of the circulating oil has an influence upon the power required to drive the pump and upon bearing friction, gear friction, cam friction, etc. It is not probable that the temperature of the oil thrown on the cylinder wall will materially affect piston friction in view of the rapidity with which a temperature approximating

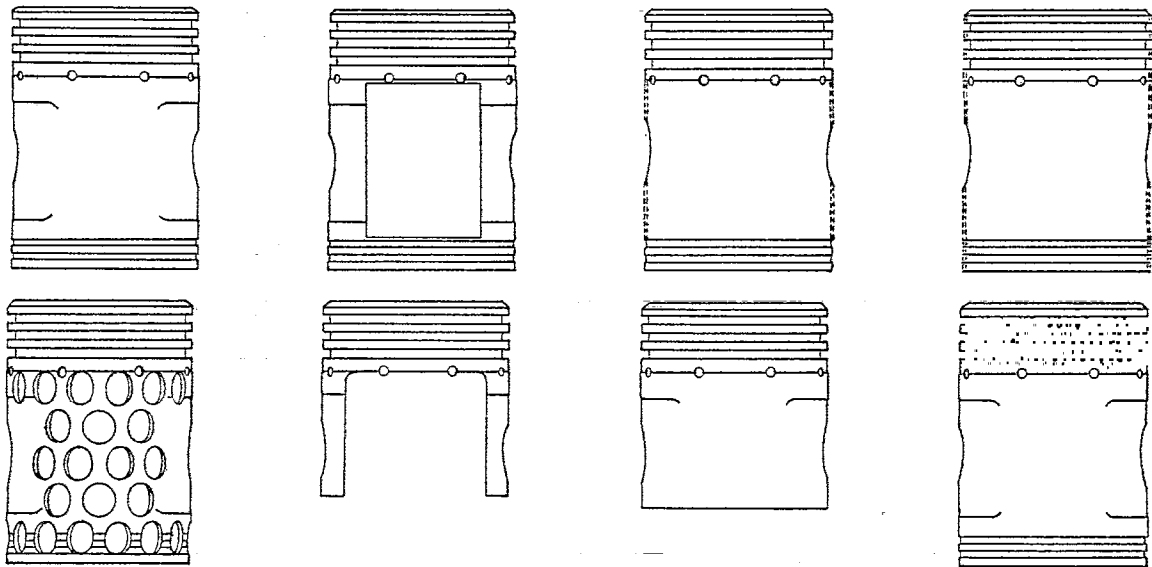

FIG. 13

Piston S: Standard; clearance, 0.005 inch; bearing area, 41 square inches; weight, 5 pounds 12 ounces.

Piston F: Forty-six 0.75-inch holes through skirt; clearance 0.005 inch; bearing area, 23 square inches.

Piston B: Thrust faces milled out; clearance, 0.005 inch; bearing area, 12.5 square inches.

Piston G: Skirt milled away; bearing area, 3 square inches.

Piston C: Clearance, part length, increased to 0.050 inch; bearing area, 4.5 square inches.

Piston H: Skirt shortened; clearance, 0.005 inch; bearing area, 25 square inches.

Piston D: Increased clearance, full length; clearance, 0.037 inch.

Piston E: Lead cast in head; clearance, 0.005 inch; bearing area, 41 square inches; weight, 12 pounds 8 ounces.

that of the cylinder wall is attained. In so far as these tests were concerned the influence of circulating oil temperature upon engine friction was of importance only because it necessitated careful control of this temperature. In most of this work, the temperature of the oil in the sump was maintained at approximately 60° C.

The standard piston and its important dimensions are shown in Figure 12. In this and other figures the designation "bearing area" is not applied to projected area but to the entire rubbing surface. This ordinarily includes all of the ground portion of the piston but of course does not include ring grooves, oil grooves, or the relieved portion around the end of the piston pin. Figure 13 shows the manner in which each piston was modified and the letter by which each piston is designated in the report.

#### CONDITIONS OF TEST

In general tests were made with each type of piston under the four following conditions of operation: (1) Pistons with full set of three rings and with valves held open so that cylinder pressures varied only a negligible amount from atmospheric; (2) pistons without rings and with valves held open so that cylinder pressure varied only a negligible amount of atmospheric;

(3) pistons with full set of three rings and with cylinder pressures varying normally; and (4) pistons without rings and with cylinder pressures varying normally. In each group of tests, measurements were made at engine speeds of 400, 600, 800, 1,000, and 1,200 R. P. M. and at jacket-water temperatures of 20, 45, 70, and 95° C. (68, 113, 158, and 203° F.).

Runs were made both with atmospheric and normal pressures in the cylinder in order that the pistons might be compared under different conditions of loading, the differences in friction presumably being the same except as affected by loading. When the pistons were operated at normal pressures and without rings, the differences in the amount of leakage past the pistons affected the pumping losses to such an extent as to mask the differences in actual friction. The information obtained in this particular group of tests though of interest deals with a phase of the problem of piston design somewhat outside the scope of this report and for this reason has not been included. The results obtained under the other three conditions of operation, however, have been plotted for each type of piston which received a complete test.

#### PISTON-RING FRICTION

Before proceeding to a discussion of the results obtained with each group of pistons it will be well to make a few comments on the subject of piston-ring friction. It has been stated that friction measurements were obtained both for pistons with and without rings. The difference in these measurements is the friction *due* to the rings but not necessarily, or probably, the friction of the rings. This is borne out by the fact that while the same rings were used with each group of pistons, the increase in friction which resulted from the addition of the rings was far from being the same. A probable explanation of this is that the rings affect the thickness and distribution of the oil film between the pistons and cylinder walls, which in turn affects the friction of the piston to an extent which depends upon its design.

#### COMPARISON OF PISTON B AND STANDARD PISTON

Piston B, as is shown by Figure 13 and Figure 14, was obtained by removing a large portion of the thrust faces of the standard piston, thus decreasing the area of the rubbing surface from about 41 square inches to about 12 square inches.

The results are shown in Figure 20 and the lower part of Figure 25. When no rings are used and the viscosity of the oil upon the cylinder walls is low, because of the high jacket-water temperature, the difference in the friction of the two pistons is negligible. At the higher viscosities, however, the friction of piston B is much less than that of the standard piston. In this connection it is of interest to note that the friction of piston B when the jacket-water temperature is 20° C. is approximately the same as that of the standard piston when the jacket-water temperature is 45° C. In other words, the effect of the change in piston construction in this particular instance was equivalent to a definite change in oil viscosity. It should be mentioned that in all of these experiments measurements of the friction at 600 R. P. M. are questionable, as there frequently was excessive engine vibration at that speed.

When the pistons were equipped with their full complement of three rings, however, the friction of piston B was higher than that of the standard piston under all of the conditions of test. From these results it would appear that with pistons of this type, reducing the thrust face area while permitting a narrow band of bearing surface to extend completely around the base of the piston tends to increase rather than decrease friction.

#### COMPARISON OF PISTON C AND STANDARD PISTON

In this piston, as is shown by Figures 13 and 15, the outside diameter of a considerable portion of the skirt was reduced, increasing the clearance to about 0.050 inch and decreasing the area of rubbing surface to about 4 square inches. Only a few measurements were made with this particular type of piston because of failure due to the reduction in the cross section of the skirt necessitated by the increase in clearance. The few measurements which had been obtained at the time of the failure of the pistons did not show anything of particular interest.

#### COMPARISON OF PISTON D AND STANDARD PISTON

This piston is shown in Figures 13 and 16. A cut was taken over the entire surface of this piston, increasing the clearance to 0.037 inch over the entire length.

Results are shown in Figures 21 and 25. When no rings are employed piston D gives much less friction than the standard piston. When the pistons are equipped with a full set of rings and compared at approximately atmospheric cylinder pressures the differences in friction are much less, and the differences are smaller yet when the comparisons are made at normal cylinder pressures.

The only conclusion that appears to be justified by this comparison is that differences in clearance may have a marked effect on friction but that with the customary ring arrangement one would not expect the effect to be large.

#### COMPARISON OF PISTON E AND STANDARD PISTON

The changes made in the various pistons altered their weight and therefore the inertia forces at any given speed. It appeared probable, however, that under the conditions of test the change in the inertia forces would have a negligible effect upon friction. As a rough means of checking the reasonableness of this assumption, friction measurements were made, using pistons E. This type of piston, differed from the standard only in the matter of weight, but in this respect it differed much more than any of the other types of piston. Vibration with these pistons was so excessive that it was not deemed advisable to make more than a brief series of tests. These tests, however, failed to show significant differences between the friction of the heavy and standard pistons. It does not appear probable, therefore, that the differences in weight of the other pistons tested had an appreciable effect upon their friction.

#### COMPARISON OF PISTON F AND STANDARD PISTON

This piston is shown in Figures 13 and 17. It differs from the standard piston only in that the rubbing surface has been reduced by the drilling of 46 holes of  $\frac{3}{4}$ -inch diameter.

Results are shown in Figures 22 and 25. Without rings, piston F gives somewhat less friction than the standard piston. When equipped with rings and operating at approximately atmospheric cylinder pressures the differences in the friction of the two pistons were rather small. With normal cylinder pressures, however, the friction of piston F was somewhat higher than that of the standard piston.

On the basis of the data here presented, it is not possible to predict whether the reduction of bearing surface by the addition of holes will increase or decrease the friction, but it does not appear probable that the magnitude of the change in friction will be great.

#### COMPARISON OF PISTON G AND STANDARD PISTON

This piston is shown in Figures 13 and 18. It will be observed that the thrust faces have been cut away to an even greater extent than in piston B and that there is no band of rubbing surface extending entirely around the base of the piston as in piston B.

Results are plotted in Figures 23 and 25. It will be noted that practically all of the comparisons show the friction to be lower for piston G than for the standard piston. In this connection it is of interest to recall that the friction of piston B was lower than that of the standard piston only when no rings were used.

As far as piston G is concerned, the conclusion appears warranted that a reduction in rubbing surface in conjunction with the removal of the band of bearing surface completely surrounding the base is likely to reduce considerably the friction both when the rings are in place and when they are removed. In this connection one should not forget the statement made earlier in the paper to the effect that the changes made in the pistons used in these experiments were usually much greater than would be permissible in service. Piston G, for example, would very likely be unsatisfactory from the standpoint of wear and gas tightness.

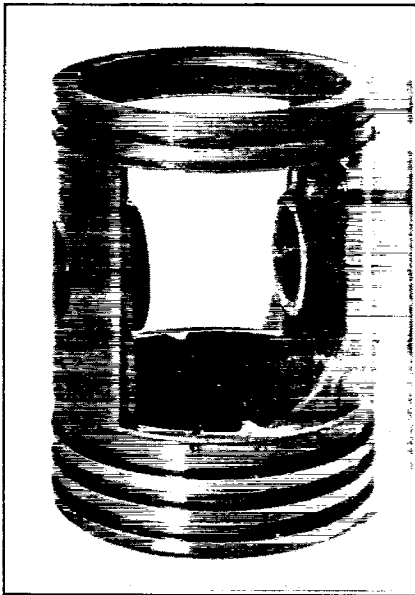

FIG. 14.—Piston B

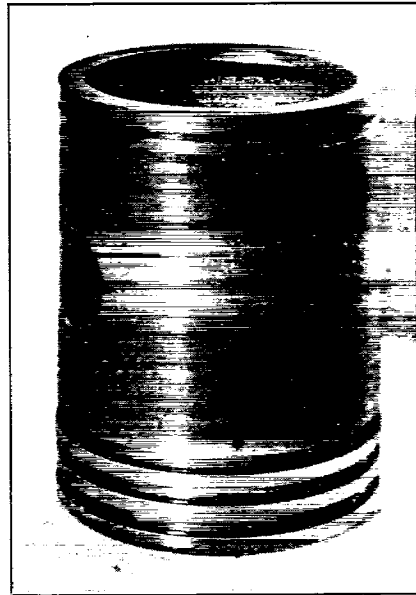

FIG. 15.—Piston C

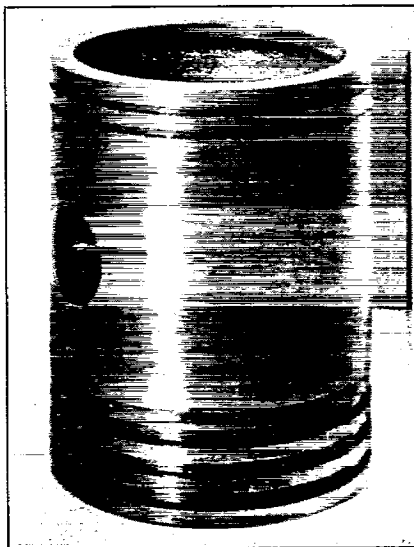

FIG. 16.—Piston D

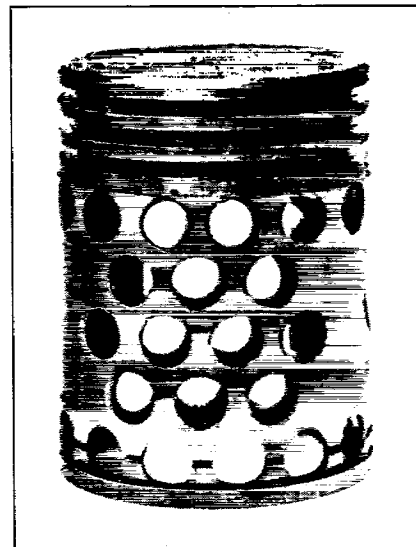

FIG. 17.—Piston F

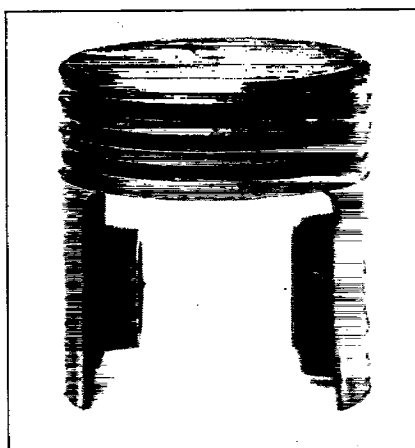

FIG. 18.—Piston G

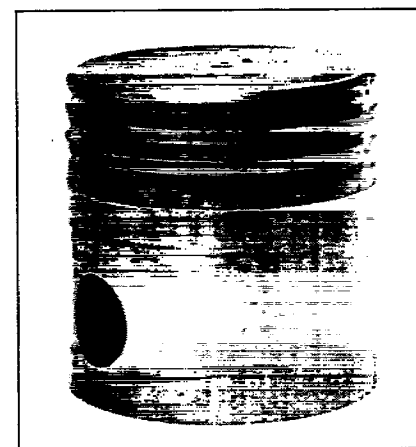

FIG. 19.—Piston H

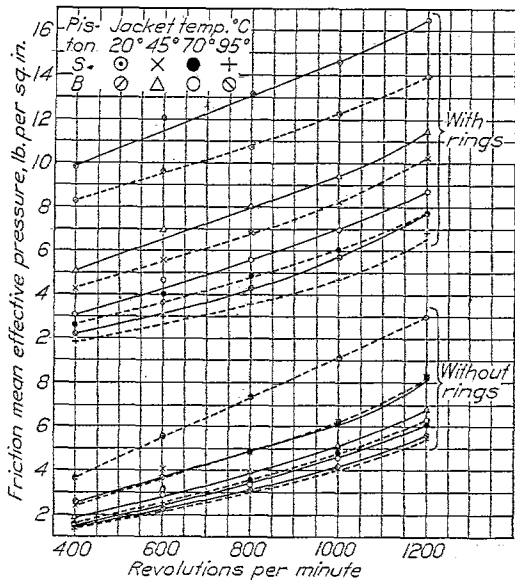

FIG. 20.—Pistons S and B

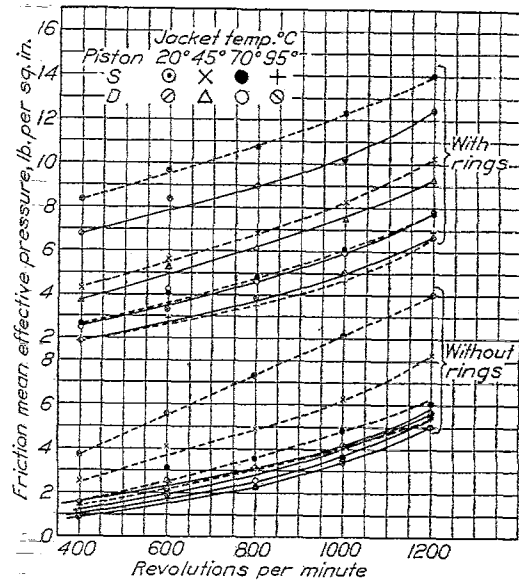

FIG. 21.—Pistons S and D

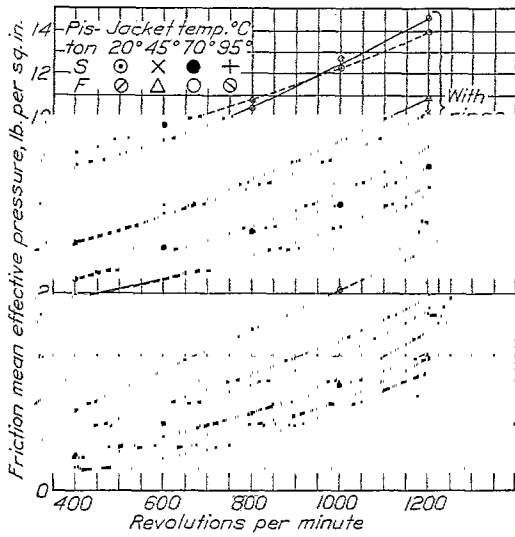

FIG. 22.—Pistons S and F

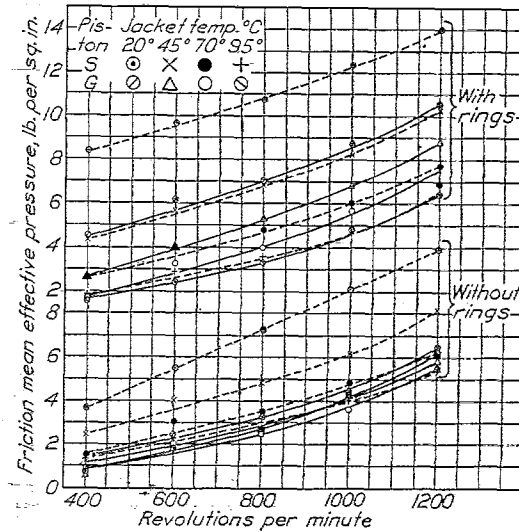

FIG. 23.—Pistons S and G

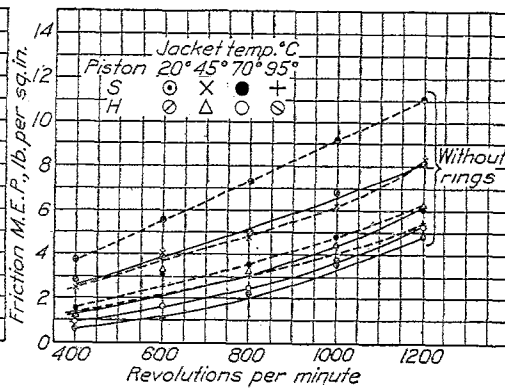
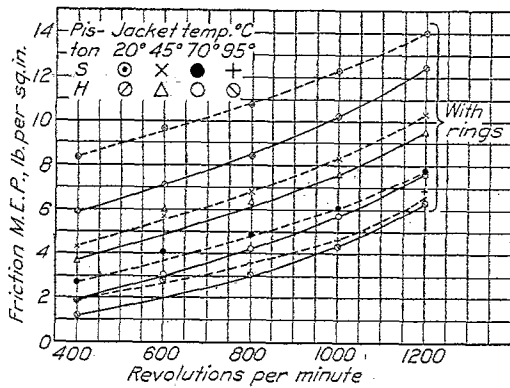

FIG. 24.—Pistons S and H: Friction mean effective pressure versus revolutions per minute; cylinder pressure nearly constant. ("No pumping loss")

### COMPARISON OF PISTON H AND STANDARD PISTON

This piston is shown in Figures 13 and 19. It is considerably shorter than the standard piston but does not differ otherwise. Results are shown in Figures 24 and 25. In general the friction is less than with the standard piston, but when rings are used and the cylinder pressures are normal the difference is rather small. The results obtained with this type of piston lead to the conclusion that a reduction in the over-all length of pistons is likely to reduce friction but that the magnitude of the change may be rather small even though the change in the area of rubbing surface is rather large.

### COMPARISON OF ALL PISTONS

Figures 26, 27, and 28 show comparisons of all the pistons for three conditions of operation and for the highest and lowest temperature of jacket water. It is not proposed to discuss in detail these comparisons but merely to point out that the employment of piston rings changes the order of the pistons as regards friction and to draw attention to the much greater friction and differences in friction at a jacket-water temperature of 20° C. than of 95° C. While the latter fact is not at all surprising, it emphasizes the folly of taking great pains to secure a piston design which will give low friction and then neglecting to use an oil of suitable viscosity or to maintain the temperature of the jacket water close to the desired value.

### GENERAL COMMENTS ON PISTON FRICTION

As was stated at the outset, this work has not been carried far enough to permit definite predictions as to the effect a given change in piston design will have upon friction. It seems desirable, however, to discuss briefly some of the factors which would appear to influence this friction and which should therefore receive attention in any further work on the subject. The magnitude of the friction undoubtedly depends upon whether there is or is not a complete film of lubricant between the cylinder walls and the piston and rings. Where there is no film one would expect the friction to be proportional to the load but independent of the area of rubbing surface. If, however, there is a complete film, then the friction will be due to the shearing of the oil and will be affected by the load on the piston only to the extent that load governs the thickness of the film. A reduction in thrust face area increases the unit pressure. An increase in unit pressure increases the rate at which the lubricant flows out from between the rubbing surfaces and hence decreases the average thickness of the lubricating film. This decrease in film thickness causes an increase in friction which counteracts to some extent the decrease in friction due to the reduction in the area of the rubbing surfaces.

Friction under conditions of complete film lubrication and the conditions essential to the maintenance of such film have been discussed on numerous occasions since attention was directed to the problem by the work of Tower as reported to the Institute of Civil Engineers (British) in 1884. It is proposed here merely to call attention to some of the respects in which piston friction differs from the simple problem of sliding friction between two flat surfaces. The piston at any instant bears only upon one side of the cylinder whereas the piston rings are intended at least to bear over their entire circumference. Loads, proportion of total surface which is bearing, film thickness, etc., are not the same for pistons and piston rings. This would offer no particular difficulty if the friction and lubrication of the piston were unaffected by the presence of the rings, and vice versa, and if conditions remained constant throughout the stroke. That such is not the case will be evident from a single illustration. Figure 29 shows a piston in four positions A, B, C, and D. At the beginning of the stroke, position A, there is clearance between the side of the piston opposite to the thrust face and the oil film on the cylinder wall. By the time that the piston has reached position B, however, a considerable amount of the space between the piston and cylinder wall is filled with a film of oil which must be sheared if the piston is to move farther. When the piston reaches position C practically the entire space between the piston and cylinder is filled with oil. It is evident that the force required to move the piston at a given rate from A to B will be different from that required to move it from B to C and still different from that required to move it from C to D. In an actual engine the force required to move

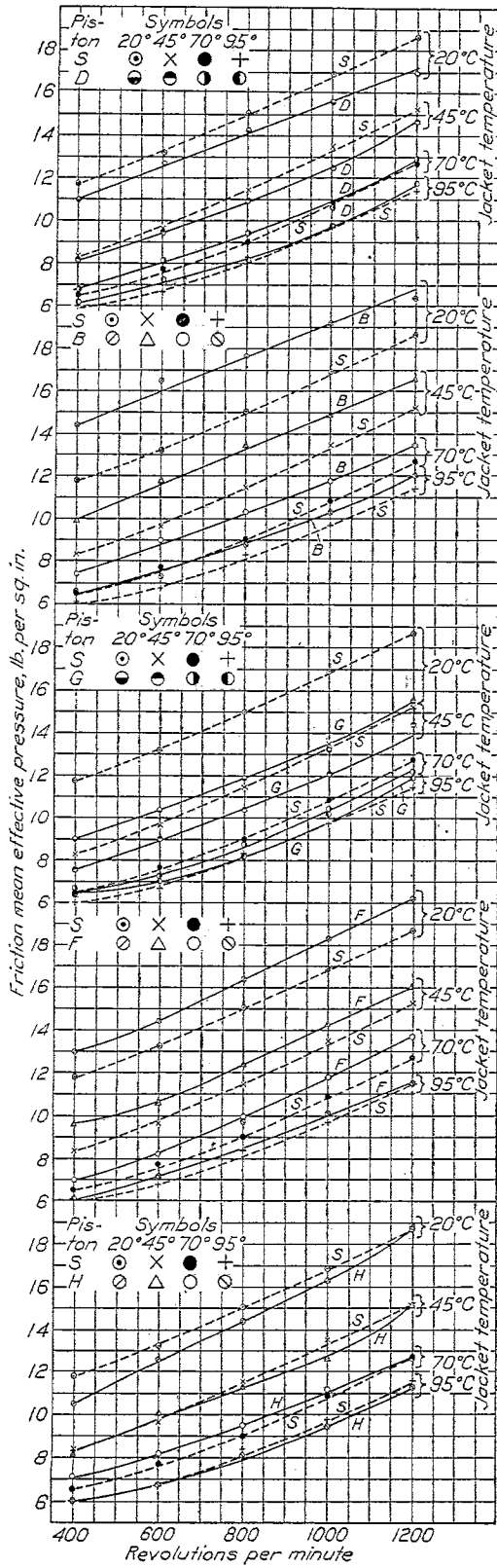

FIG. 25.—Pistons with rings; cylinder pressure varying normally. ("With pumping loss")

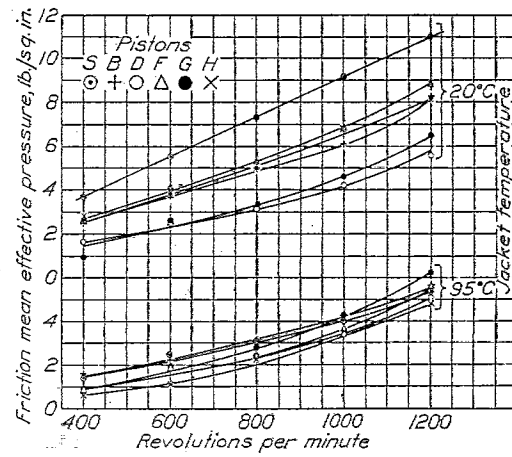

FIG. 26.—Pistons without rings; cylinder pressure nearly constant. ("No pumping loss")

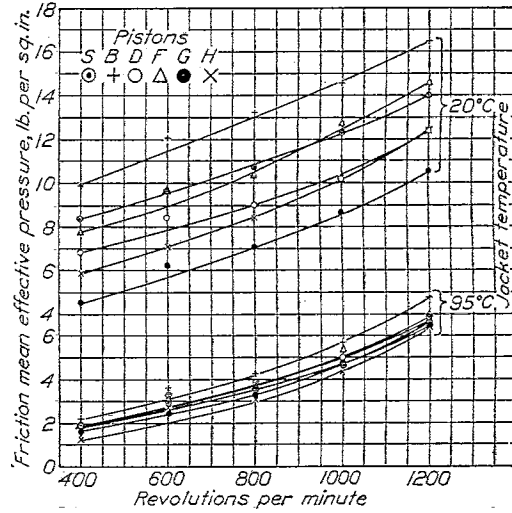

FIG. 27.—Pistons with rings; cylinder pressure nearly constant. ("No pumping loss")

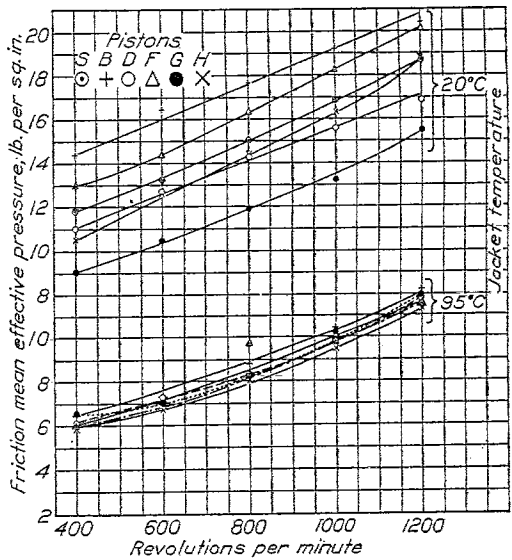

FIG. 28.—Pistons with rings; cylinder pressure varying normally. ("With pumping loss")

the piston is affected by the fact that the piston speed varies throughout the stroke. Piston design and ring design govern the distribution of the lubricant as well as the extent to which it can collect between the piston and cylinder walls. These remarks will serve to indicate the complexity of the relation between piston design and piston friction and the danger of drawing conclusions from two brief a series of tests.

Figures 30 and 31 present relations of considerable interest, although the numerical values shown are not generally applicable. The friction values are the same as given in Figures 20 to 24 for the condition of minimum pressure variation in the cylinder—that is to say, with valves held open and spark plugs removed. The friction is plotted against viscosity on the assumption that the oil film on the cylinder wall is at the same temperature as the jacket water. In all probability the actual difference between these two temperatures is small.

As has been stated already, the temperature of the oil entering the engine was maintained constant so that the temperature of the jacket water affected only the viscosity of the oil upon the cylinder walls and hence only the friction of pistons and rings. As the viscosity of the oil film between two rubbing surfaces is decreased the friction is decreased and in the unobtainable ideal condition of complete film lubrication with an oil of zero viscosity the friction would be

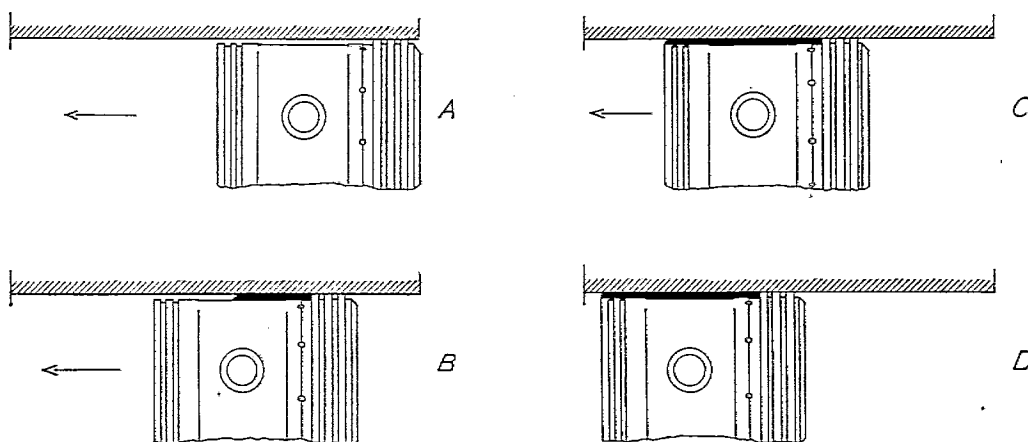

FIG. 29.—Illustrating the collection of oil on the unloaded side of piston

zero. The fact that, in actual operation, the film breaks down and the friction increases long before the viscosity becomes zero must be recognized. However, complete film lubrication is believed to obtain over a wide range of viscosities and, from measurements of friction within this range, it is possible to plot a curve showing the relation between viscosity and friction. It seems a justifiable assumption to project this curve back to zero viscosity. This has been done in Figures 30 and 31, although measurements were not made for a sufficient number of viscosities to make the exact location of the curves definite. It is believed, however, that the intersection of the curves with the line of zero viscosity is an approximate measure at least of the friction of the engine minus the friction of pistons and rings. It is not the actual friction value which is of particular interest in connection with these curves but the fact that at a given speed nearly the same friction was obtained at zero viscosity with all the pistons tested both with and without rings. This suggests at least that conditions of complete film lubrication prevailed during practically all the tests.

Figure 32 has also been presented more as an illustration than because of any particular significance in the actual values of friction as plotted. The lower curve represents zero piston friction as taken from Figures 30 and 31. The curve immediately above it shows the lowest values of friction with pistons and rings obtained in this group of tests, whereas the third curve shows the highest values. These curves do not represent limiting values but merely suggest the extent to which piston and ring friction may vary. They emphasize also the importance of such further research as will make it possible to predict definitely the effect of a given change in piston design upon piston friction.

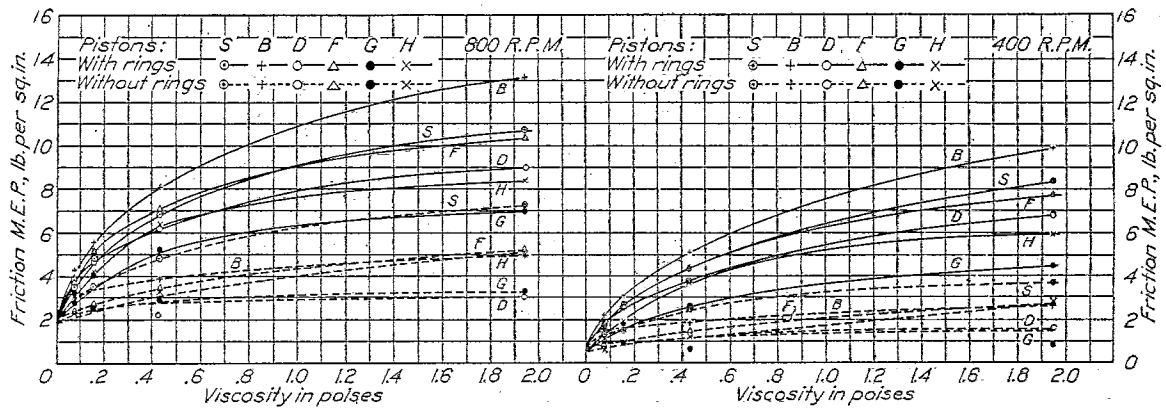

FIG. 30.—Pistons with and without rings; cylinder pressures nearly constant; ("no pumping loss"); 400 and 800 revolutions per minute

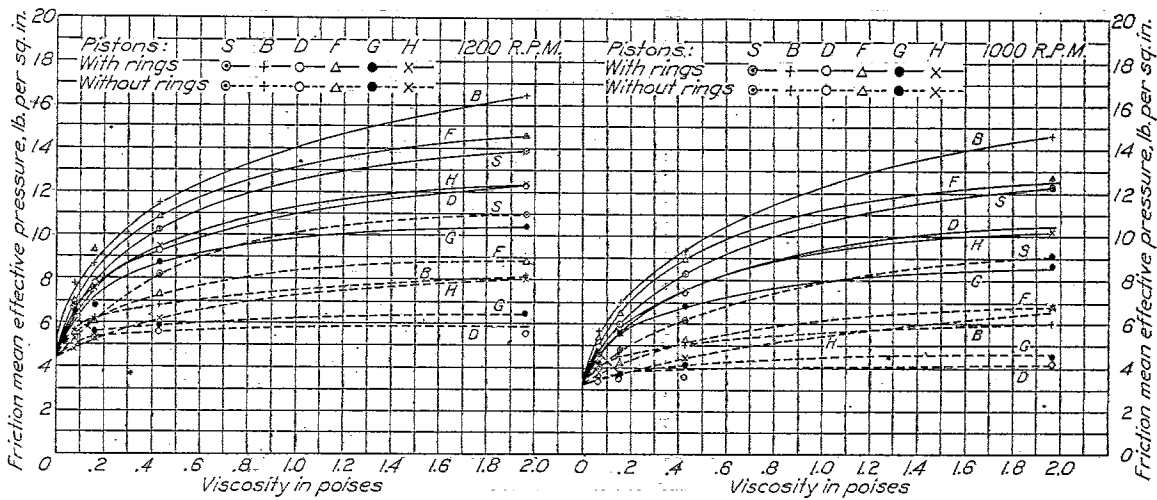

FIG. 31.—Pistons with and without rings; cylinder pressures nearly constant; ("no pumping loss"); 1,000 and 1,200 revolutions per minute

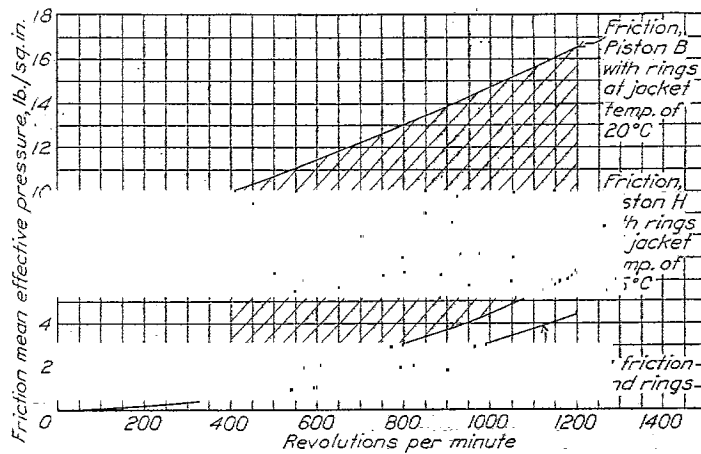

FIG. 32.—High and low values of friction of pistons and rings

## CONCLUSIONS

This report has shown over a wide range of conditions the differences in friction produced by various changes in piston design. From this work the following conclusions may be drawn: (1) With pistons of the type tested, reducing the thrust face area while permitting a narrow band of bearing surface to extend completely around the base of the piston tends to increase rather than to decrease friction. (2) A reduction in rubbing surface in conjunction with the removal of the band of bearing surface completely surrounding the base is likely to reduce friction very materially. (3) Differences in the clearance between the piston and cylinder walls may have a marked effect on friction, but with the usual ring arrangement one would not expect the effect to be large. (4) It is not probable that the presence of a large number of holes in the skirt of a piston will reduce its friction to any great extent. (5) Reducing the over-all length of a piston is likely to reduce friction, but the magnitude of the change may be small even though the change in the area of rubbing surface is rather large. While these experiments covered a wide range of conditions it is entirely possible that some of these conclusions might not hold for radically different designs or conditions of operation.

One fact strikingly shown in these tests is that the friction chargeable to piston rings depends upon piston design as well as upon ring design. This is probably due to the effect of the rings upon the thickness and distribution of the oil film, which in turn affects the friction of the piston to an extent which depends upon its design.

## BIBLIOGRAPHY

- SPARROW, S. W. Correcting Horsepower Measurements to a Standard Temperature. N. A. C. A. Technical Report No. 190. 1924.
- GAGE, VICTOR R. A Study of Airplane Engine Tests. N. A. C. A. Technical Report No. 46. 1920.
- GAGE, VICTOR R. Some Factors of Airplane Engine Performance. N. A. C. A. Technical Report No. 108. 1921.
- RICARDO, HARRY R. The High Speed Internal Combustion Engine. *The Automobile Engineer*, July, 1925.
- MOSS, H. and STERN, W. J. The Mechanical Efficiency of an Internal Combustion Engine. *The Automobile Engineer*, March, 1925.
- RICARDO, HARRY R. Piston Design, with Special Reference to Aluminum Pistons. *The Automobile Engineer*, March, 1917.
- RICARDO, HARRY R. Piston Design. *The Automobile Engineer* October, 1918.
- RICARDO, HARRY R. High Speed Internal Combustion Engines. *The Automobile Engineer*, July, 1918.
- STANTON, T. E. The Friction of Pistons and Rings. *The Engineer*, January 16, 1925.