

REPORT No. 232

FUELS FOR HIGH-COMPRESSION ENGINES

By STANWOOD W. SPARROW
Bureau of Standards

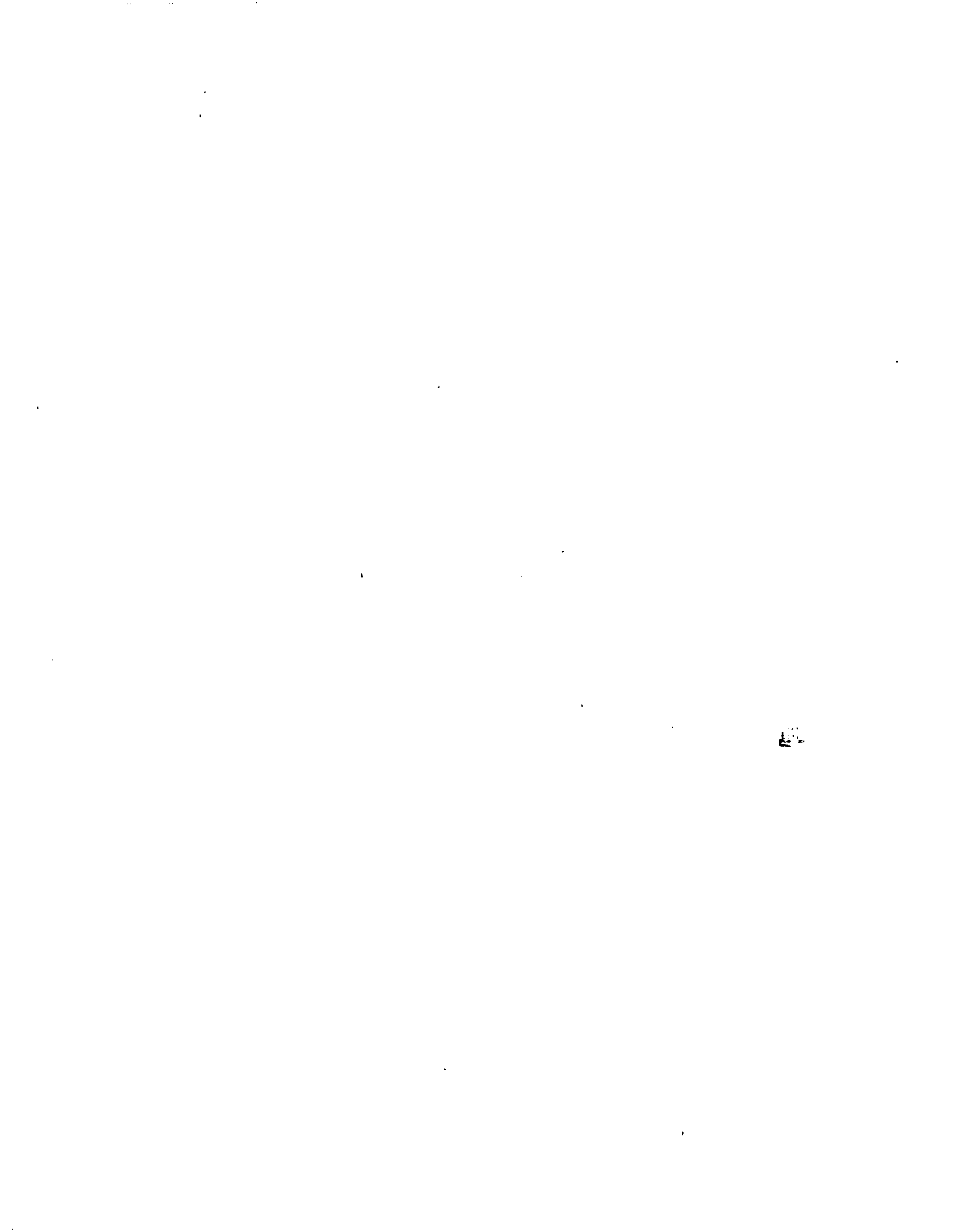

REPORT No. 232

FUELS FOR HIGH-COMPRESSION ENGINES

By STANWOOD W. SPARROW¹

SUMMARY

This report is based very largely on results of tests made at the Bureau of Standards during 1922, 1923, and 1924 under research authorization of the National Advisory Committee for Aeronautics.

From theoretical considerations one would expect an increase in power and thermal efficiency to result from increasing the compression ratio of an internal-combustion engine. In reality it is upon the expansion ratio that the power and thermal efficiency depend, but, since in conventional engines this is equal to the compression ratio, it is generally understood that a change in one ratio is accompanied by an equal change in the other. Tests over a wide range of compression ratios (extending to ratios as high as 14:1) have shown that ordinarily an increase in power and thermal efficiency is obtained as expected provided serious detonation or preignition does not result from the increase in ratio.

There are marked differences between fuels as regards the conditions under which they detonate or preignite. It follows that the employment of a high-compression ratio is contingent upon securing a fuel which is suitable in its resistance to preignition and detonation, and which at the same time possesses the other qualities essential to a satisfactory engine fuel.

This report emphasizes the fact that there may be a difference between a fuel's ability to resist detonation and its ability to resist preignition. Although this report is primarily a general discussion of the properties essential to a satisfactory fuel for high-compression engines, certain fuels, benzol and alcohol in particular, are discussed in some detail.

INTRODUCTION

During the World War the Bureau of Standards conducted an extensive investigation of fuels for aircraft engines. Results were published in Report No. 47 of the National Advisory Committee for Aeronautics entitled "Power Characteristics of Fuels for Aircraft Engines." That this report (No. 47) does not mention detonation or preignition is significant as indicating that at that time the importance of these phenomena was not generally appreciated.

As aviation developed, attempts to use high-compression ratios became more frequent, and in consequence preignition and detonation were encountered more frequently. Ricardo in Great Britain and Midgley in the United States were among the first to draw attention to the seriousness of detonation. The first work at the Bureau of Standards distinctly devoted to fuels for high-compression engines is discussed in Reports 89 and 90 of the National Advisory Committee for Aeronautics. It consisted of tests of two fuels, Alcogas and Hecter, in an aviation engine of 7.2 compression ratio. Subsequently a more general study of fuels for high-compression engines was authorized by the National Advisory Committee for Aeronautics and from time to time the performance of special fuels has been measured for the Bureau of Aeronautics of the Navy Department.

While a single-cylinder engine has been employed extensively in this research, results have been checked frequently by means of multicylinder aviation engines. In some cases the immediate problem has been to select the most suitable fuel for an engine of a given compression ratio, whereas in other cases it has been to determine the best combination of compression ratio

¹ The late S. M. Lee and Messrs. Brooks, Bender, Paul, and Ragsdale have had a major share in the obtaining of the information contained in this report.

and fuel for a given purpose. While the number of fuels investigated has not been large, it is believed that sufficient information has been obtained to form a satisfactory basis for discussing the characteristics of a fuel which determine its suitability for use in high-compression engines.

As already mentioned, the characteristics of a fuel with reference to preignition and detonation are of the utmost importance in determining how high a compression ratio can be used satisfactorily. Hence these two phenomena will be discussed first.

PREIGNITION—DEFINITION AND DESCRIPTION

"Preignition" as used in this paper is defined as ignition from any source prior to the time at which ignition is desired. The term "autoignition" ordinarily is used with reference to an engine such as the Diesel, in which ignition is effected by the generation of heat within the engine cylinder. Preignition usually is a special case of autoignition. If an engine continues to fire after the ignition switches are opened, it is an evidence of autoignition, but not necessarily of preignition. The autoignition may occur when the piston is nearly at top center, somewhat after the time at which the igniting spark would occur in normal operation. The operation of the engine may be uninfluenced by the fact that had the spark not occurred autoignition would have taken place. However, when an engine gives evidence of autoignition, preignition may reasonably be expected to follow as soon as conditions become slightly more severe.

The usual consequences of serious preignition are a decrease in engine power and abnormally high pressures and temperatures of the working fluid. Evidence that preignition is occurring is usually furnished by a decrease in power and high-heat dissipation to the jacket water. Evidence that preignition *has* occurred may be furnished by melted spark-plug electrodes, burned valves, fractured or melted portions of piston heads, etc. Similar effects sometimes result from detonation, as will be discussed later.

WHY PREIGNITION CAUSES HIGH PRESSURES, TEMPERATURES, AND LOSS OF POWER

To understand why preignition causes an increase in maximum temperature two facts should be borne in mind. The first is that the increase in temperature produced by combustion is practically independent of the temperature before combustion, and hence is practically the same regardless of whether the charge is ignited at the normal point in the cycle or earlier, as is the case when the engine preignites. The second is that the ratio between the absolute temperature after compression and that before compression is (1) independent of the temperature before compression and (2) always greater than one. For purposes of illustration, assume

M = increase in mixture temperature due to combustion,

t = mixture temperature at the beginning of compression,

a = ratio between absolute temperatures at end and beginning of compression stroke,

then, in light of the foregoing statements, if combustion occurs at the end of the compression stroke the maximum temperature will be $(at + M)$. If under conditions of severe preignition combustion occurs at the beginning of the compression stroke, then the temperature at the beginning of the compression stroke will be $(t + M)$ and the maximum temperature will be $a(t + M) = at + aM$. In this case the increase in maximum temperature due to preignition will be $(at + aM) - (at + M) = M(a - 1)$. Ordinarily preignition occurs during the compression stroke rather than at the very beginning, and the ratio to which the mixture is compressed after combustion is less than the compression ratio of the engine. The increase in temperature due to preignition will, therefore, depend upon the ratio to which the mixture is compressed after combustion and will be somewhat less than $M(a - 1)$.

Preignition will increase the pressure at the end of the compression stroke in approximately the same ratio that it does the absolute temperature. This is a consequence of the fact that preignition does not alter appreciably the amount of charge which enters the engine in unit time and that at constant volume pressure is directly proportional to the absolute temperature.

The effects of preignition may be small or large, depending upon the severity of the phenomenon. If the preignition is slight the sole consequence may be a small reduction in engine power and economy comparable to what would result from a too far advanced spark. Mild preignition, however, is very apt to develop into that which is severe. A probable sequence of events is as follows: The first occurrence of preignition, even though it is slight, causes an increase in the average temperature of the cycle. This causes the phenomenon to take place earlier in the succeeding cycle. The process continues until eventually the fresh charge is ignited as it enters the cylinder and no power is developed. Figure 1 shows an actual indicator card taken with an engine preigniting. The power developed in the preigniting cylinder was negative, that is to say, a portion of the power developed by the other cylinders was employed in overcoming the resistance which it offered.

CAUSE OF PREIGNITION

Preignition, as contrasted with ignition from an electric spark, is the result of heating a portion of the charge to such a temperature that it ignites. There are many factors which influence the temperature reached by portions of the charge prior to ignition. These include the temperature of the air entering the carburetor, the amount of heat supplied to the charge in its passage to the cylinder, the compression ratio, the amount and temperature of the exhaust gases in the clearance space, and the amount and rate of heat transfer to the charge from various hot portions of the combustion chamber.

In most instances the source of preignition is some portion of the combustion chamber whose temperature normally is much higher than that of other portions of the combustion chamber or of the charge itself. In such cases preignition depends upon the temperature of the hot point, the temperature of the charge, and the rate at which the charge passes the hot point.

There are reasons to believe that slight preignition may often exist without being recognized as such and without causing any appreciable harm. This is possible if the actual amount burned before the charge is ignited from its normal source is sufficiently small. Engine speed may be important in its effect upon the time available per cycle during which the slight preignition may reach serious proportions. That such is the case is suggested by the fact that engines which operate at normal speeds without any sign of preignition or autoignition will continue to fire after the ignition circuit has been opened and the engine speed has dropped to a very low value. There is no apparent reason why any portion of the combustion chamber under these conditions should be hotter than or even as hot as at normal speed and full load. The probable explanation is that at low speeds the time interval corresponding to a few degrees of crank motion is sufficient to permit a hot portion of the combustion chamber to ignite the charge. At normal engine speeds the time interval corresponding to the same number of degrees might be too short to permit ignition.

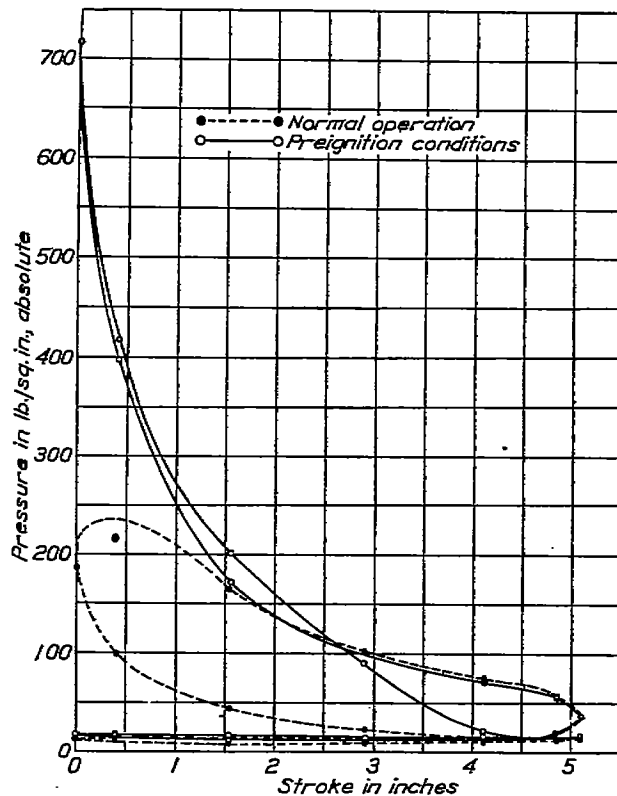

FIG. 1.—Altitude, 7,000 feet. Barometer, 57.8 cm Hg. Compression ratio, 8.3. R. P. M., 1,600

The velocity with which the charge flows to the engine has an influence upon the consequences of preignition. If this velocity is greater than the velocity with which flame is propagated, even though preignition in one cylinder of a multicylinder engine may be so severe that the charge is ignited as it enters, there may be no external evidence other than a loss in power. At lower charge velocities, however, the flame may rush back and cause explosions in manifold and carburetor. Either condition is likely to be encountered in the normal range of engine speeds.

COMPRESSION RATIO AND PREIGNITION²

It is generally—and in so far as is now known correctly—believed that the likelihood of preignition increases with the compression ratio of an engine. Not all of the changes which accompany an increase in compression ratio, however, increase the engine's tendency to preignite. For this reason an increase in ratio often increases troubles due to preignition to a much less extent than anticipated. As has been shown the ratio between the temperature at the end and at the beginning of the compression stroke increases with increase in ratio. Hence, charge temperatures during the compression stroke are higher the higher the compression ratio. This to be sure increases the tendency for the engine to preignite. On the other hand, because of the decrease in clearance volume with increase in ratio and the decrease in temperature of the exhaust gases, less heating will result from the mixing of the fresh charge with the gases remaining in the clearance space. This tends to decrease the temperature of the charge during the compression stroke and consequently the engine's tendency to preignite. Because of the increase in expansion ratio (expansion and compression ratios are equal in conventional engines) the average temperature during the cycle decreases with increase in compression ratio. Hence, the temperature of spark-plug electrodes, valves, etc., will be correspondingly decreased and likewise the probability that they will cause preignition.

COMPARING FUELS WITH RESPECT TO PREIGNITION

It is not altogether certain by what characteristics of a fuel its tendency to preignite can best be gauged. At present the so-called spontaneous ignition temperatures appear to form the most satisfactory basis for estimating the *relative* ability of various fuels to resist preignition. Spontaneous ignition temperatures, however, can not be taken as indicating the temperatures at which ignition will take place in the engine cylinder and, in fact, values obtained by various investigators differ considerably. This can be attributed to differences in methods of measurement.

A rather brief but nevertheless fairly complete review of work on the spontaneous ignition temperatures of liquid fuels is given by Moore in "The Automobile Engineer" of May, 1920. He defines the temperature of spontaneous ignition as "the temperature at which a substance surrounded by oxygen or air at the same temperature will burst into flame without the application of any spark or other local high temperature." Such a condition may exist when starting an engine of the Diesel type, as the charge in such case is likely to be at a temperature which is nearly uniform throughout and considerably higher than the temperature of surrounding metal parts. In the normal operation of most engines some portion of the combustion chamber is hotter than the charge, so that the condition of "no local high temperature" is not met.³

Moore, in the article previously referred to, discusses the spontaneous ignition temperatures of blended fuels and draws attention to the very interesting condition shown graphically in Figure 2. In this figure, which is typical of all the blends tested by Moore, the spontaneous ignition temperature of the blend is shown to be very nearly the same as that of the constituent which has the lower ignition temperature except when this constituent forms only a small proportion of the blend. The spontaneous ignition temperature then becomes nearly the same as that of the constituent having the higher ignition temperature. This change of spontaneous ignition temperature is brought about by a rather small change of blend proportions. It is rather to be expected that this characteristic will be somewhat less marked in actual engine

² For a more detailed discussion, see Report No. 205 of the National Advisory Committee for Aeronautics, entitled "The Effect of Changes in Compression Ratio upon Engine Performance."

³ See also "The Self-Ignition Temperature of Fuels" by H. T. Tizard. The Automobile Engineer, May, 1923.

operation for the reason that preignition often results from the high temperatures due to detonation and detonation varies much more uniformly with change of blend proportions than do spontaneous ignition temperatures.

At the present time the Bureau of Standards is developing an instrument for use in comparing fuels with respect to preignition. A description of the instrument in its present form will serve to illustrate the objects sought and probable method of use even though the instrument as finally developed may be radically different. As will be noted in the sketch, Figure 3, the instrument consists of a housing which may be screwed into the engine cylinder and plugs of various cross section and lengths which may be clamped in this housing.⁴ Essentially the device is a definite artificially constructed hot spot whose high temperature is attained by exposing a large amount of metal to the burning charge while preventing, so far as is feasible, the conduction of heat from this metal.

There are two general methods by which this instrument may be used in comparing fuels. The first method consists in determining for each fuel which of the various plugs can be used

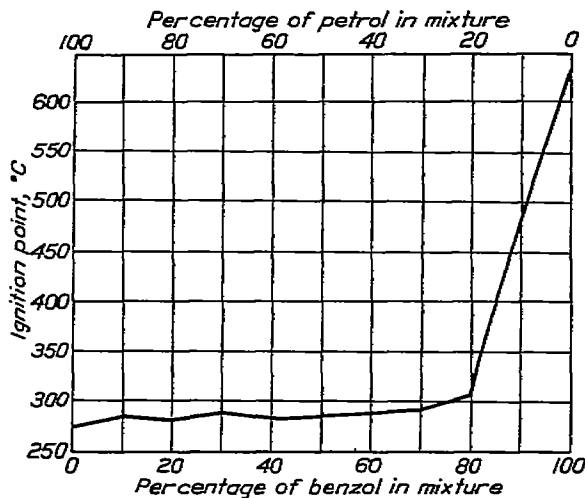

FIG. 2.—Ignition points of mixtures of benzol (crystallizable) and petrol. (From "Spontaneous Ignition-Temperatures of Liquid Fuels" by Harold Moore. "The Automobile Engine," May, 1920.)

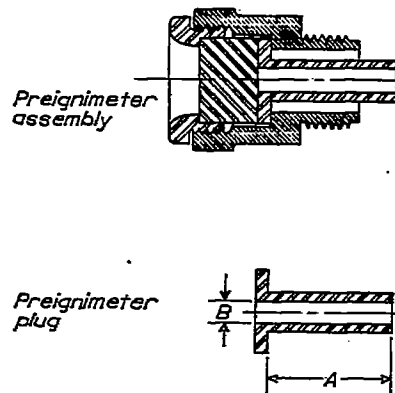

FIG. 3.—(Plugs differing in their tendencies to cause preignition are obtained by varying dimensions A and B.)

without causing preignition. Comparisons are made under certain fixed conditions of engine speed, load, and compression ratio. In the second method the same plug is used with both fuels and the comparison is based upon the relative loads or compression ratios with which satisfactory operation is obtained.

It is to be expected that the relative grouping of fuels as regards preignition will be the same with either method of test. If it is not it suggests that the relative merits of these fuels may not be the same for different types of engines. When fuels are compared on the basis of permissible load or compression ratio but without using a preignimeter, there is no assurance as to what is the hottest portion of the combustion chamber or as to its constancy. The preignimeter to a great extent overcomes this difficulty and should make it possible to obtain measurements of greater reliability.

DETONATION—DEFINITION AND DESCRIPTION

Detonation may be defined as a combustion phenomenon whose best recognized manifestation is the ringing sound which sometimes accompanies a too far advanced spark. In the motor-car engine the noise itself is objectionable, whereas in aviation engines detonation is to be feared because of the extremely high pressure and temperatures which it causes. Serious detonation, aside from its destructive effects, is objectionable in that it results in a decrease in power and an increase in the amount of heat rejected to the jacket water which, in turn, necessitates greater radiator capacity.

⁴ Another possibility is to use a single plug electrically heated. The temperature could then be changed at will and the amount of change could be estimated rather closely from electrical measurements.

DETONATION—METHODS OF MEASUREMENT

Ricardo rates fuels by what he calls "toluene values." He defines the toluene value as "the tendency of a fuel to detonate in terms of its equivalent toluene content, taking standard aromatic free gasoline as having zero toluene value and toluene as having a value of 100." It should be noted that toluene values are not independent of the method of measurement. Ricardo used both a variable compression and a supercharging stratified charge engine. In one instance a toluene value of 28 was obtained with one engine and a value of 18 with the other. For another fuel the value obtained with one engine was 35 and with the other 24. Ricardo made tests of a large number of fuels and assigned to them toluene values. This work is described at length in the *Automobile Engineer* of February to August, 1921, and in *Automotive Industries* of April to September, 1921.

Midgley rates detonation by means of what he terms a "bouncing pin."⁵ The instrument is screwed into the cylinder and is so constructed that a portion of it forms what is essentially a small thin-walled section of the combustion chamber. One end of the bouncing pin rests upon this wall. The pin is so guided that its motion is perpendicular to this wall and motion in this direction is resisted by a spring which when sufficiently deflected closes an electric circuit. As long as the circuit remains closed current flows through a solution of 10 per cent sulphuric acid. As a result gas is evolved and this is collected and measured. The amount of gas evolved in unit time serves as a basis for rating the detonation.

As has been stated, in so far as aviation engines are concerned, the seriousness of detonation lies in its destructive effect. Direct comparisons of this effect have been made by noting the time required to rupture a diaphragm of given thickness when the diaphragm is exposed

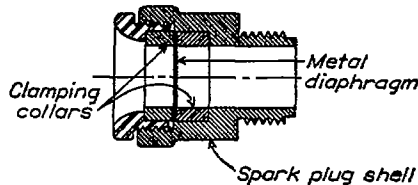

FIG. 4.—Device for comparing maximum pressures

to the pressures in the engine cylinder. The device used at the Bureau of Standards is shown in Figure 4, and is described in Technical Note No. 101 of the National Advisory Committee for Aeronautics. In this device the metal disk which serves as a diaphragm is mounted between two metal washers in a spark-plug shell. The thickness is selected so that when the disk is subjected to the explosion pressure of the engine the exposed

portion will be sheared from the rim in a comparatively short time. Aluminum disks ranging in thickness from 0.010 inch to 0.040 inch have been used for the most part.

Characteristics of fuels with respect to detonation may also be compared by means of an engine having a compression ratio so high that satisfactory full throttle operation is not possible with any of the fuels under comparison. For each fuel the maximum throttle opening at which the engine can operate with no detonation or with no serious detonation is determined and the indicated horsepower developed under these conditions is measured. The comparison of the fuels is based upon the measurements of horsepower thus obtained. It will be noted that this method requires for its application an independent method for determining the presence of detonation or of "serious" detonation.

DIFFICULTIES IN DISTINGUISHING BETWEEN PREIGNITION AND DETONATION

The chief difficulty in measuring preignition and detonation lies in the fact that although these are distinct phenomena each may produce, and often is accompanied by, the other. It is important, however, to distinguish between the two phenomena when rating fuels, as the value of a fuel in one type of engine may be dependent upon its resistance to preignition and in another type upon its resistance to detonation.

Both preignition and detonation are affected by spark advance, fuel-air ratio, and general engine condition. The usual requirement that comparisons be made under the same conditions is applicable, but this does not mean necessarily with the same spark advance or the same fuel-air ratio. It usually means with the fuel-air ratio giving maximum power or some definite

⁵ Journal of the Society of Automotive Engineers, January, 1922.

percentage of maximum power and with the spark advance giving the maximum power with this ratio. If there are large differences between the rates of flame spread of two fuels, then there will be large differences in the spark advances at which the two fuels should be compared. This discussion of the difficulties in measuring preignition and detonation has not been introduced with any thought that these difficulties are insurmountable but rather to emphasize the fact that a necessary preliminary to such measurements is often a rather complete series of tests at various throttle openings, fuel-air ratios, and spark advances.

From the foregoing it is evident that the ability of an engine to operate at a certain compression ratio and compression pressure does not prove that another type engine will operate satisfactorily with the same fuel at the same ratio and pressure. Usually, however, if two fuels are compared in engine A and the performance of one of these fuels in engine B is known, it is possible to estimate rather closely the performance of the other fuel in engine B.

Before considering specific fuels it seems advisable to discuss briefly some of the other factors which affect the value of a fuel for use in internal-combustion engines. No attempt will be made to list these factors in the order of their importance as this depends upon the service to which the engine is devoted. Availability, price, calorific value, explosive range, distillation range, latent heat of evaporation, freezing point, separation, viscosity, corrosiveness, specific gravity, chemical composition, and rate of flame propagation are to be discussed.

AVAILABILITY

An aviation engine is to a considerable extent built to "fit" its fuel. Its compression ratio is as high as is considered safe for this particular fuel, its carburetor jets are of the size which will meter the proper amounts of this fuel. It is essential, therefore, that this or a fuel which can be used equally satisfactorily in the same equipment be available wherever the airplane is likely to land.

From a military standpoint it is essential to know to what extent a fuel will be available in time of war. Some European countries import the bulk of their fuel. In the event of war this source of supply might be entirely cut off. Benzol, xylol, and toluol possess desirable antiknock properties, but the objection is frequently raised that in the event of war the output of toluol, at least, might be required for the manufacture of explosives.

PRICE

An airplane permits more rapid transportation than is possible by other means. The higher its speed the more desirable for this purpose it becomes.

Any increase in engine power which does not involve an increase in the over-all weight of the airplane makes possible an increase in speed. Obviously, if one fuel permits an engine to develop more power than another, it will command a much higher price as the cost of fuel is but a small percentage of the total cost of operating an airplane. No argument is necessary as to the value of any changes in fuel characteristics which increase the reliability of the power plant. In the case of a combat airplane differences in fuel characteristics are of the utmost importance. The lack of a few horsepower may cause the death of the pilot and the destruction of the airplane. For these reasons it does not now appear probable that the selection of fuel on the basis of price is likely, except when the fuels under consideration are of nearly equal merit.

CALORIFIC VALUE

Goodenough⁶ defines calorific power as follows: "The union of a combustible with oxygen produces heat, and the heat thus generated when 1 pound of combustible is completely burned is called the heating value or calorific power of the combustible." When not otherwise specified, calorific power is understood to be based on unit weight. It is equally important, however, to know the calorific power of a fuel per unit volume and per unit volume of combustible mixture.

⁶ See Marks' Mechanical Engineers Handbook, footnote on p. 363.

For aviation engines it is desirable that the fuel be of high calorific power per unit weight as minimum weight is one of the chief aims of both the engine and airplane designer. High calorific power per unit volume is also desirable as it permits the use of a small fuel tank with a consequent low weight and wind resistance. Probably the most important value, however, is that based on unit volume of combustible mixture. Upon this value the power obtainable from a given engine depends. The fuel ordinarily constitutes a small proportion of the total volume of the charge. As the volume of charge received by the engine in unit time is but slightly dependent upon the fuel used, then it follows that the power developed by the engine will be almost directly proportional to the calorific value of the fuel per unit volume of combustible mixture.⁷ Ricardo, from his investigations,⁸ concluded that the total energy obtainable per unit volume of combustible mixture differs by less than 3 per cent for mixtures of air and hexane, heptane, benzene, toluene, xylene, or ethyl alcohol.

Hydrogen furnishes a rather good illustration of the necessity for specifying whether calorific values are based upon unit weight, unit volume, or unit volume of combustible mixture. The calorific value of hydrogen per pound is nearly three times as great as that of gasoline, whereas the calorific power of a cubic foot of combustible mixture of gasoline and air is between 10 per cent and 20 per cent greater than that of a cubic foot of combustible mixture of hydrogen and air.

EXPLOSIVE RANGE

The term "explosive range" refers to the limits between which the fuel vapor-air mixture is combustible. Narrowing this range increases the difficulty of engine operation. Much of the data which are available on the explosive range of mixtures of gasoline vapor and air have been derived from laboratory experiments with glass bombs in which conditions were considerably different from those which exist in the engine cylinder, both as regards the rate of heat dissipation, turbulence, and amount of inert gas present. Obviously such measurements are not directly applicable to engine operation. It is reasonable to expect, however, that a fuel shown by such tests to possess a greater explosive range than another will have a greater range than the other when used in the engine.

DISTILLATION RANGE

Distillation characteristics of a fuel are ordinarily shown by curves in which temperatures are plotted against "per cent distilled." These curves are valuable as a means of identifying fuels and indicating their suitability for a given type of service.

It is quite generally believed that the more volatile a fuel the more suitable it is for aviation work. To a certain extent this is true, inasmuch as the more readily a fuel vaporizes the more easily is it distributed and prepared for combustion. It is somewhat less generally appreciated that a fuel may be objectionable from the standpoint of being too volatile. The objection to such a fuel arises from the fact that it vaporizes in the carburetor and fuel lines, thus restricting the flow of fuel and interfering with the metering characteristics of the carburetor. This condition is commonly known as "vapor lock." What makes this trouble particularly serious is the difficulty of detecting it. Vapor may form in a fuel line and restrict the flow to such an extent as to cause the performance of the engine to be extremely erratic, and yet this vapor may entirely disappear before an examination of carburetor and fuel lines can be made.

In 1924 the United States Government had two specifications for aviation gasoline. The more volatile fuel was termed "fighting grade" and was intended to be used "as a fuel for fighting airplanes where the highest efficiency is required." The superiority of this fuel to the "domestic grade" for military purposes is questionable in the light of present knowledge as to the seriousness of this trouble from vapor lock. Combat airplanes are capable of climbing very rapidly. As a result there is a considerable reduction in the absolute pressure on the fuel system before

⁷ It is assumed throughout the discussion that the combustible mixture consists of fuel and air. If the mixture consists of fuel and oxygen its calorific value per unit volume of combustible mixture will be much higher.

⁸ See *Automotive Industries*, July 7, 1921. Certain investigators, however, report having found an increase in volumetric efficiency to result from the use of alcohol and they have attributed this increase to the high latent heat of evaporation of the alcohol.

the temperature of the fuel drops in accordance with the low temperatures which prevail at high altitudes. This is the condition most likely to produce trouble from vapor lock and the more volatile the fuel the more easily is such trouble produced.

Extremely high volatility is also undesirable in a fuel because of the resultant waste from evaporation in storage and because of the fire hazard. To minimize the danger from fire repeated attempts have been made to adopt Diesel or other engines using heavy oils instead of gasoline to aviation uses. The ignition temperature of such fuels may be even lower than that of gasoline but the possibility of explosions or of the extremely rapid spread of fire is much less since less vapor is present.

LATENT HEAT OF EVAPORATION

The latent heat of evaporation of a fuel at a given temperature is the amount of heat required to vaporize a unit weight at that temperature. A low latent heat is a desirable characteristic in so far as it reduces the amount of heating of the charge necessary to secure adequate vaporization. Ricardo, in certain experiments with alcohol,⁹ found that power increased as the richness of mixture was increased until the mixture had been enriched to a far greater extent than would appear necessary from the chemical characteristics of the fuel. This he attributed to an increase in volumetric efficiency brought about by the large amount of heat abstracted from the charge in the vaporization of the alcohol. This amount would increase with enrichment of the mixture. This is an instance where high latent heat might be considered of value inasmuch as it permits the development of higher power than would otherwise be possible.

It may be well at this time to mention an extremely undesirable effect which may result from the drop in temperature due to the vaporization which takes place in the intake system of an engine. The effect referred to is the formation of snow. This snow is very apt to collect around the engine throttle although it may cling to any portion of the intake system. Two conditions are necessary for its formation, (1) the air entering the carburetor must contain a considerable amount of moisture, and (2) the vaporization must cause the temperature of the charge or of a portion of the charge to drop below the freezing point of water. Obviously the remedy is to supply sufficient heat to prevent such a temperature drop. An amount of heat equal to the latent heat of evaporation should be adequate for this purpose.

The effect of this snow formation upon engine operation is very serious. It throttles and thus decreases the power of the engine. This may eventually force the airplane to the ground because of insufficient power. When the changes in power take place suddenly, conditions are most serious. This occurs when a considerable quantity of snow collects, and subsequently becomes dislodged due to vibration of the engine, or movement of the throttle, or a change in manifold suction. The effect is that of an uncontrolled and rapidly fluctuating throttle. Needless to say, flight under such conditions is extremely dangerous.

FREEZING POINT

If a fuel freezes at any of the temperatures encountered in normal service, this fact constitutes a serious objection to its use. Most fuels satisfactory in other respects are satisfactory in this also. Benzol is an exception, freezing at temperatures normally prevailing at moderately high altitudes. Fuel sold under the designation "motor benzol" ordinarily contains sufficient toluol to lower the freezing point materially.

SEPARATION

There may be some conditions under which one constituent of a blended fuel separates from the remainder. These will be discussed later in more detail in relation to certain of the more common blends. The merits of a blended fuel disappear when the fuel ceases to be a blend. An unusually serious situation results when one of the constituents of the blend is an anti-knock agent. The use of the fuel from which the antiknock constituent has separated is likely to result not only in poor operation but in engine destruction.

⁹ See *Automotive Industries*, July 7, 1921.

VISCOSITY

So long as a fuel can be metered satisfactorily in the conventional type of carburetor, its actual viscosity is of minor importance. Information should be available, however, as to the extent to which viscosity is affected by temperature and if a change in fuels is to be made the differences in their viscosities should be known. The magnitude of the influence of changes in viscosity upon the rate of fuel flow depends upon the design of the fuel-metering device. If the design is such that viscosity materially affects the rate of fuel flow, then when a change in fuels is made the change in carburetor jet sizes must be governed by the differences in viscosity as well as in the density of the fuel and its combining proportions.

CORROSIVENESS AND TENDENCY TO FORM GUMS

Engine failure is more likely to prove disastrous in the case of the airplane than in other types of automotive transportation. Hence the tendency of a fuel to cause corrosion or to form gums is more objectionable when the fuel is to be used for aviation than when it is to be used for other purposes. Unfortunately some of the fuels which have desirable antiknock characteristics seem to be rather unsatisfactory with respect to corrosiveness and the tendency to form gums. It is believed that in many cases this condition could be remedied by further refining if the demand were sufficient to warrant it.

SPECIFIC GRAVITY

Mention is made of specific gravity merely to call attention to the fact that it is not a reliable indication of the value of a fuel although at one time it was much used for that purpose. Provided the comparison is made between hydrocarbon fuels of the same series an idea as to the relative volatility of such fuels may be obtained from their specific gravities. This is not true when the fuels are not of the same series. Benzol, for example, has a higher specific gravity than the usual grade of motor-car gasoline but it is much more volatile. At the present time distillation data have replaced measurements of specific gravity almost entirely as a means for comparing fuels.

A change of specific gravity will change the metering characteristics of the carburetor. This influence is ordinarily considered in connection with the change of viscosity, which also results from a change of fuel.

CHEMICAL COMPOSITION

By ultimate analysis and other chemical and physical tests it is usually possible to determine the chemical composition of a fuel, its proportion of aromatics, etc. This information may be of scientific interest and is an aid in predicting the fuel's performance. Usually, however, it is easier to measure performance directly than to make a determination of chemical composition. Hence complete chemical analyses are not ordinarily made in the examination of a fuel to determine its suitability for use in high-compression engines. Nevertheless measurements of acidity, unsaturated compounds, and sulphur frequently form a part of acceptance tests.

RATE OF FLAME PROPAGATION

This property has received a great deal of attention at the hands of those studying the properties of fuels. Measurements usually have been made by means of tubes or bombs of the constant pressure or constant volume types. Unquestionably such measurements have furnished a great deal of valuable information as to the nature of combustion and of such phenomena as preignition and detonation. With respect to efficiency, however, Ricardo arrived at the following conclusion: "No fuel has yet been found whose rate of burning is too low to permit of maximum efficiency being obtained in the highest-speed engine yet tested." This statement should not be taken as indicating that the rate of burning never has an appreciable influence on efficiency, for there certainly have been cases where the limit of operating leanness has been that at which the charge was ignited in the manifold by flame rushing back from the cylinder. This occurred because the charge had not been completely burned by the end of the expansion stroke. A more rapid rate of burning would have made possible operation with leaner mixtures and hence better economy.

"MOTOR BENZOL"

Perhaps one of the best known fuels for high-compression engines is "motor benzol," which ordinarily contains not only benzol but also xylol and toluol. This fuel was employed satisfactorily long before its antiknock properties were appreciated or the desirability of such properties understood. Both the Bureau of Aeronautics of the Navy Department and the National Advisory Committee for Aeronautics have supported the tests of this fuel which have been made at the Bureau of Standards. Since the proportions of the various constituents which compose motor benzol are not fixed, the characteristics of each lot of fuel might be expected to be different. Fortunately the properties of the constituents are similar and differences between the products of several refiners proved to be rather small.

The fact that benzol had been used extensively as a fuel for internal-combustion engines rendered unnecessary an examination of all the properties of a fuel which have been mentioned. Hence the following discussion will confine itself very largely to such information as was derived from the above-mentioned study of the suitability of benzol as a fuel for high-compression engines.

In 1923 the question of availability was taken up with the Bureau of Mines and some of the large producers of motor benzol. There was fairly general agreement that at least 50,000,000 gallons of motor benzol were annually available for fuel. Not all of this benzol, however, is as free from corrosive effects as is aviation gasoline. Moreover, the belief is rather widespread that in the event of war the entire production of motor benzol would be required for the manufacture of explosives. At that time a rather careful analysis of the facts seemed to indicate that this fear was not well grounded. Nevertheless it is shared by many who have given considerable thought to the subject. It is undoubtedly true that in the event of war large quantities of toluol would be employed in the manufacture of explosives. If, as a result, the motor benzol available contained less toluol, its freezing point would be higher. This raising of the freezing point would be extremely objectionable in so far as the use of the fuel in aircraft is concerned.

Figure 5 shows some of the results obtained with the single-cylinder engine, indicated mean effective pressures and specific fuel consumptions in pounds per indicated horsepower-hour being plotted against pounds of fuel per hour. The general procedure was to use the single-cylinder engine as far as possible, checking the conclusions by means of tests of multicylinder engines. In most cases the data given in Figure 5 were obtained with blends containing the smallest amount of benzol which would permit satisfactory (free from severe preignition or detonation) operation at the given compression ratio. The curves of Figure 6 are derived from those of Figure 5. The upper curve of specific fuel consumption in Figure 6 is based upon a constant fuel-air ratio, the ratio being approximately that giving maximum power. The lower is based upon a mixture leaned until the power is 99 per cent of maximum. In previous work this 99 per cent value has proved to be a satisfactory basis for comparisons of specific fuel consumption. These curves were plotted originally to show the changes in power and specific fuel consumption which result from changes in compression ratio. They are included in this report as evidence that the fuels used at each ratio were satisfactory in preventing serious preignition and detonation. Had such not been the case the curves probably would have shown abrupt changes in curvature.

Figure 7 shows the percentage of motor benzol required at various compression ratios, based upon the results of this particular group of tests. With another benzol or another type of engine or under different conditions the percentages of benzol required very probably would be different. Nevertheless the figure gives a general idea of the changes in benzol content that are likely to be necessitated by a given change in compression ratio. No attempt was made to use a blend with the 11.5 ratio, but it is evident from the figure that a blend containing a small amount of gasoline would have been satisfactory.

The amount of power developed when using benzol, gasoline, or a blend of the two is very nearly the same, provided there is in no case serious preignition or detonation. One would expect a slight increase in specific fuel consumption with each increase in the benzol content

of the blend inasmuch as the calorific value of motor benzol is somewhat less than that of gasoline. While some of the multicylinder-engine tests have shown tendencies in this direction, the differences have been small. No evidence of this tendency was noted in the single-cylinder engine tests whose results are given in Figures 5, 6, and 7.

From the results of these tests and from such other information as is available it appears that blends of motor benzol and gasoline are reasonably satisfactory with respect to distillation

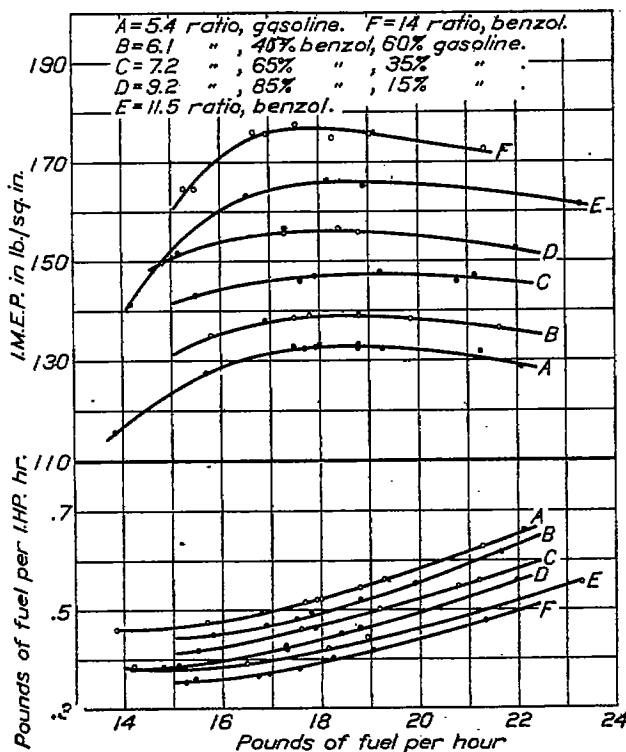

FIG. 5.—Power and fuel consumption at various compression ratios

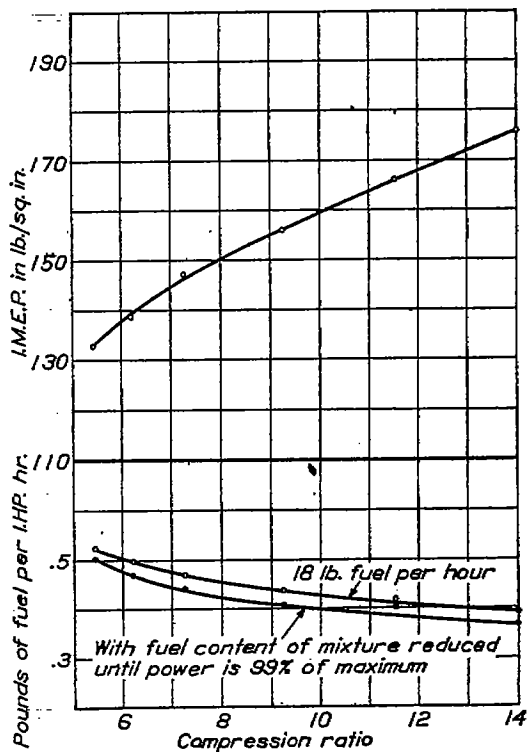

FIG. 6.—Effect of compression ratio on power and fuel consumption (benzol-gasoline blends)

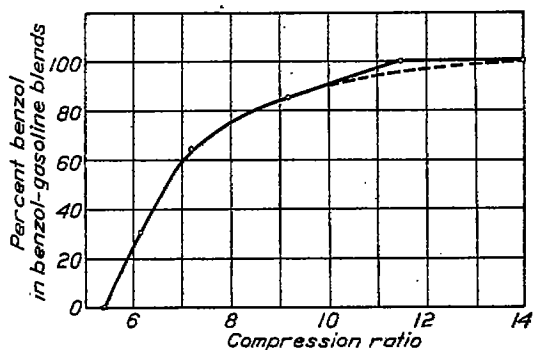

FIG. 7.—Percentages of "Motor Benzol" in benzol-gasoline blends One-cylinder engine. Bore, 5 inches. Stroke, 7 inches. R. P. M., 1,500. (Percentages will be different for other types of engines.)

range, latent heat of evaporation, viscosity, and rate of flame propagation. Maximum power was obtained regardless of whether the fuel employed was gasoline, benzol, or a blend of the two. This indicates that under engine conditions the rate of flame propagation is about the same for benzol as for gasoline.

Some of the motor benzol which is now being marketed is less satisfactory from the standpoint of corrosive action than aviation gasoline. This may be due to the lack of sufficient demand for benzol of this quality rather than to any serious difficulty involved in getting rid of the offending constituents. In this connection it is well to note that benzol is a solvent for certain substances which are unaffected by gasoline. One of the first consequences of its use in a system in which gasoline has been used previously may be to rid the system of certain accumulated deposits. This sometimes clogs fuel lines and carburetor jets and causes the engine operator to believe that the fuel is highly corrosive, whereas the products are in reality the result of the cleaning action of the benzol.

Probably the chief objections to the use of motor benzol or blends of motor benzol and gasoline are that freezing points and separation temperatures are rather high. As these depend

upon the grade of gasoline and the composition of the benzol, measurements made with one lot of motor benzol may not be even approximately correct for another lot, the constituents of which are in different proportions. The following data were obtained from measurements of several blends. Motor benzol A was obtained from a different refiner than motor benzol B. The X gasoline conforms to Government specifications for domestic aviation gasoline and the same grade was used in all the blends.

TABLE 1

40 per cent benzol A; 60 per cent gasoline X: -11° C., slightly milky. -22° C., more milky. -35° C., formation of solid.	40 per cent benzol B; 60 per cent gasoline X: -1° C., milky. -27° C., very milky. -29° C., formation of solid.
30 per cent benzol A; 70 per cent gasoline X: -12° C., slightly milky. -32° C., milky. -42° C., formation of solid.	30 per cent benzol B; 70 per cent gasoline X: +1° C., milky. -34° C., formation of solid.
20 per cent benzol A; 80 per cent gasoline X: -26° C., slightly milky. -45° C., formation of solid.	20 per cent benzol B; 80 per cent gasoline X: -24° C., slightly milky. -43° C., formation of solid.

It is difficult to determine definitely what degree of "miliness" is serious. Certain it is that a pilot would be reluctant to operate under conditions such that the blended fuel gave any indications of being abnormal in appearance or performance.

ETHYL ALCOHOL

The possibility of the extensive use of ethyl alcohol as a fuel for internal-combustion engines has been frequently discussed. Its attractiveness consists in what might be termed its "potential availability." In an emergency it could be produced in practically unlimited quantities, inasmuch as it is not dependent upon an exhaustible source of supply as are petroleum products. Such a course, however, would reduce the amount of food products and its economic soundness is open to question.

It has also been known for a long time that ethyl alcohol can be employed satisfactorily with compression ratios much higher than are permissible with gasoline as a fuel. Its low calorific value and consequent high specific fuel consumption, however, have tended to prevent its adoption for aviation work. Another objection to its use is that starting is more difficult than when gasoline is the fuel. These objections are met to some extent by blending with gasoline, using only as much alcohol as is necessary to give the desired antiknock value. If alcohol is to be blended with gasoline its water content must be very low unless an additional blending agent is used, and until a few years ago the cost of large quantities of alcohol of the desired freedom from water would have been prohibitive.

Figures 8, 9, and 10 show results of tests made at the Bureau of Standards. These received support from the same sources as the benzol tests and were conducted in much the same fashion. Ordinarily the amount of alcohol in the blend was just sufficient to prevent serious detonation. Alcohol alone, however, was used in one group of runs at the 5.4 compression ratio. A comparison of this group of runs with those made with gasoline as a fuel shows the high specific fuel consumption which the use of alcohol entails. Figure 9 is based upon the data given in Figure 8 and shows that a minimum specific fuel consumption is obtained at a compression ratio of about 7. At higher ratios the amount of alcohol which it is necessary to use in the blend in order to obtain satisfactory operation is so great that its low calorific value overbalances the decrease in specific fuel consumption in pounds per horsepower-hour which results from the increase in expansion ratio.¹⁰ It should be observed that the indicated mean effective pressure continues to increase with increase in ratio up to the highest ratio employed. For this reason it might prove desirable for certain classes of service, in short flights, for example, to employ a high-compression ratio and use alcohol as a fuel in spite of the high specific fuel consumption which would be entailed. Before leaving Figure 9 in should be pointed out that this figure

¹⁰ In conventional engines compression ratio and expansion ratio are equal.

does not show the effect of a change in compression ratio alone but this effect superimposed upon the effect of a change in blend proportions. Had alcohol alone been used as fuel there would have been a decrease in specific fuel consumption with each increase in ratio.

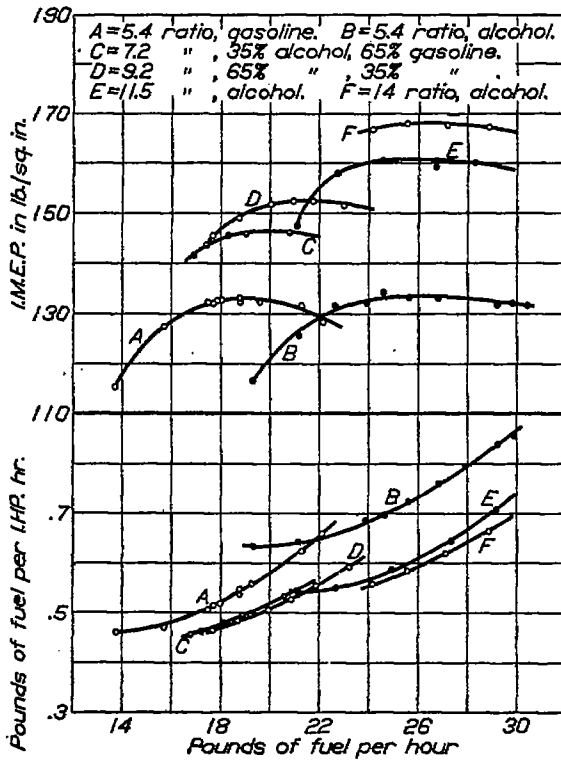

FIG. 8.—Power and fuel consumption at various compression ratios.

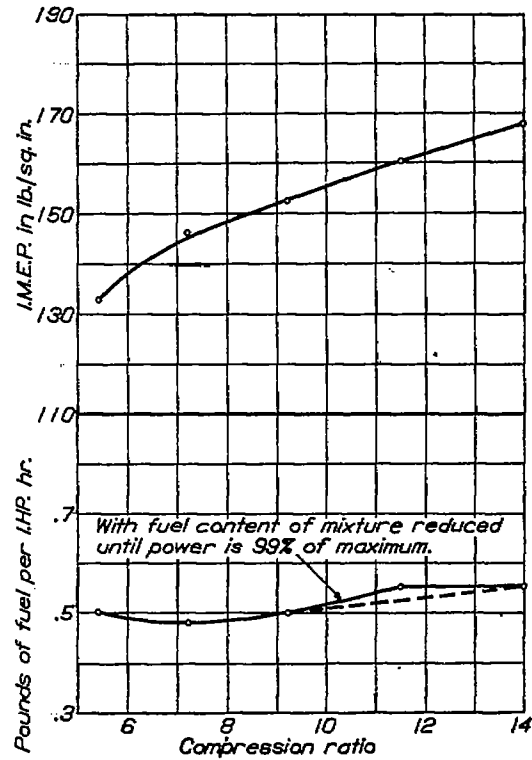

FIG. 9.—Effect of compression ratio on power and fuel consumption (alcohol-gasoline blends). One-cylinder engine. R. P. M., 1,600. Bore, 5 inches. Stroke, 7 inches.

Figure 10 shows the percentages of alcohol required under the conditions of these tests. As was mentioned in the discussion of the benzol-gasoline blends, somewhat different percentages are likely to be required with engines of other types or under different conditions of operation.

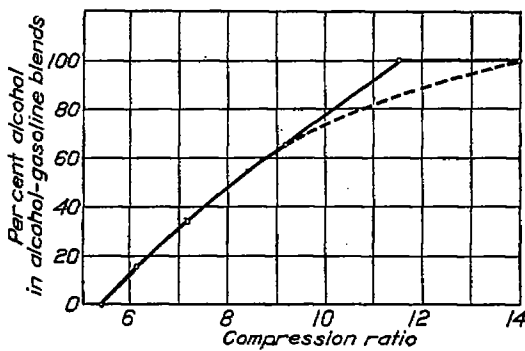

FIG. 10.—Percentage of alcohol in alcohol-gasoline blends. One-cylinder engine. Bore, 5 inches. Stroke, 7 inches. R. P. M., 1,600. (Percentages will be different for other types of engines.)

Nevertheless the figure gives a general idea of the change in alcohol content likely to be necessitated by a given change in ratio.

In these tests some difficulty was experienced in starting the engine when alcohol alone was used as a fuel. This was probably due to the absence of low boiling-point constituents, the boiling point of alcohol being about 78° C. No such difficulty was encountered in the use of the alcohol-gasoline blends and the alcohol itself was entirely satisfactory after the engine had been in operation a few minutes.

Inasmuch as the latent heat of evaporation of alcohol is much higher than that of gasoline, it would probably prove desirable to heat the charge to a greater extent when using alcohol than when using gasoline. Ricardo¹¹ emphasizes the influence which the high latent heat of evaporation has upon the volumetric efficiency of an engine. As has been stated, he found that with alcohol enrichment of the mixture far beyond the point at which maximum power

¹¹ "Recent Research Work on the Internal Combustion Engine," by H. R. Ricardo, Transactions of the Society of Automotive Engineers, vol 17, 1922, part 1, p. 1.

would normally be expected gave an increase in power. This he attributed to an increase of volumetric efficiency brought about by an increase in the amount of heat withdrawn from the charge in the vaporization of the alcohol. No such effect, however, was noted in the tests discussed in this report.

There were no indications of excessive corrosion due to the use of the alcohol, but the tests were not sufficiently extensive to give conclusive evidence in this respect. As is the case with benzol, alcohol acts as a solvent for certain substances not affected by gasoline. When employed in a system previously used for gasoline, foreign matter may be dislodged and clog fuel lines or strainers. This occasionally is attributed to the corrosive action of the alcohol, when in reality it is a result of its cleaning action.

With alcohol a somewhat greater spark advance was required than with aviation gasoline. This would indicate that the ignition velocity of alcohol is somewhat less than that of gasoline. The difference, however, is probably too slight to influence the performance appreciably.

The freezing point of alcohol is below -100°C ., well below any temperature likely to be encountered in flight. With blends of alcohol and gasoline the situation is much less attractive, although these would offer no difficulty if the alcohol were free from water and remained so. Unfortunately, however, alcohol has a strong tendency to absorb water from its surroundings and its miscibility with gasoline decreases with such absorption. After a study of the various factors influencing the stability of gasoline-alcohol-water mixtures, it was concluded that the minimum temperature of complete solubility increases—

- (1) With increasing water content,
- (2) With increasing gasoline content,
- (3) With increasing gravity of gasoline.

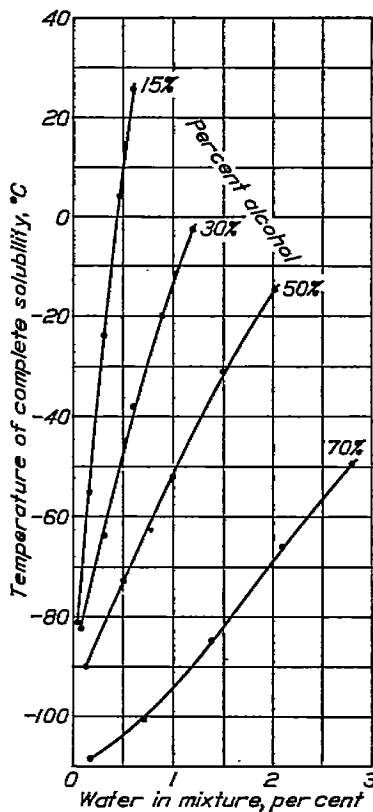

FIG. 11

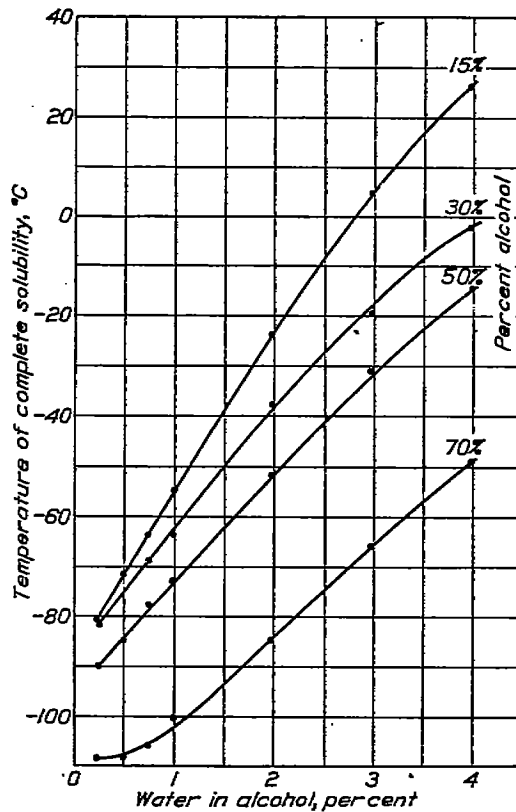

FIG. 12

Solubility curves of alcohol-X gasoline mixtures

Other investigators have found it possible to diminish materially the minimum temperature of complete solubility by adding small percentages of certain substances such as benzol and ether.

Tests on the rate of absorption of water by gasoline-alcohol-water mixtures indicate that this rate increases—

- (1) With decreasing water content of mixture,
- (2) With increasing alcohol content of mixture,
- (3) With increasing humidity.

Results of miscibility tests are shown in Figures 11 and 12. The alcohol as originally received was 99.9 per cent, the gasoline, an aviation gasoline whose distillation characteristics are given in Figure 13. Figures 11 and 12 are both based upon the same data, the abscissæ in one being the percentage of water in the mixture and in the other the percentage of water in the alcohol. Obviously when alcohol-gasoline blends are employed, special precautions should be taken to keep the fuel free from water. This unquestionably is an objection to the use of these blends. If, however, they should be employed extensively it is probable that little difficulty would be experienced in effecting a considerable reduction in the amount of water that ordinarily finds its way into storage and service tanks.

Separation of the blend constituents is most likely to take place at high altitudes because of the low temperatures which prevail there. When separation does take place, alcohol, being the heaviest constituent, will be used first. As the alcohol is the antiknock constituent, serious consequences are likely to result when the airplane reaches low altitudes if the alcohol content of the blend has been reduced. Even at high altitudes considerable difficulty might be experienced in engine operation since for operation with alcohol alone the fuel orifice should be larger than for operation with alcohol-gasoline blends.

SPECIAL ANTIKNOCK CONSTITUENTS

From time to time it has been claimed that material changes in the performance of gasoline would result from the addition of small percentages of certain substances. Very frequently these claims have proved to be unwarranted. It is known, however, that there are certain substances which when added to gasoline materially decrease its tendency to detonate even though they constitute but one or two per cent of the mixture.

Mention of this type of antiknock agent is made primarily to call attention to their apparent decrease in efficacy when it becomes necessary to use them in rather high percentages in order to meet the demands of extremely high-compression ratios. The following table which is based on the work of Midgley,¹² will serve as an illustration:

TABLE 2

ALCOHOL-KEROSENE BLEND

Alcohol, by volume	Kerosene, by volume	Determined equivalent; xylidine in kerosene, by volume
<i>Per cent</i>	<i>Per cent</i>	<i>Per cent</i>
15	85	2.30
25	75	4.60
35	65	7.20
50	50	12.60

The last column shows the percentage of xylidine which must be added to kerosene to give the same antiknock characteristics as are obtained by the addition of the percentages of alcohol which are shown in the left-hand column. One might expect that if 2.30 parts of xylidine gives kerosene the same antiknock value as 15 parts of alcohol, then $\frac{2.30}{15} \times 50$ parts xylidine should give the same antiknock characteristics as 50 parts of alcohol. $\frac{2.30}{15} \times 50 = 7.7$,

¹² Journal of the Society of Automotive Engineers, June, 1922.

whereas the table shows 12.6 parts of xylydine to be necessary. This can be explained partially by the fact that with the alcohol-kerosene blend when the percentage of the knock-suppressing constituent has been increased from 15 to 50, then there is only $\frac{50}{85}$ or 59 per cent as much of the constituent whose knock is to be suppressed. With the xylydine-kerosene mixture there is $\frac{37.3}{97.4}$ or 90 per cent as much of the constituent whose knock is to be suppressed. It is evident that one should guard against overoptimism in estimating the probable performance of an antiknock agent of this type in an engine of extremely high-compression ratio.

One example will serve to illustrate the great value of an antiknock agent of the type described. At the present time most aviation engines employ a compression ratio which permits full throttle operation with aviation gasoline without serious detonation. Occasionally a pilot finds himself where aviation gasoline is not available and is forced to use the grade ordinarily supplied to motor cars. This is likely to result in severe detonation and its consequences may prove serious. It is entirely feasible, however, for the pilot to carry a small amount of one of these very effective antiknock agents and be prepared for such an emergency.

CONCLUSIONS

Much progress has been made in the development of fuels for high-compression engines. In further efforts along this line it should be borne in mind that freedom from detonation does not necessarily give freedom from preignition. It moreover should be realized that, although a fuel possesses satisfactory characteristics from the standpoint of preignition and detonation, it is not a suitable fuel for high-compression engines unless it is satisfactory with respect to the other qualities which have been discussed.

BIBLIOGRAPHY

- Influence of Various Fuels on Engine Performance. By H. R. Ricardo. *The Automobile Engineer*, February, 1921, to August, 1921. *Automotive Industries*, April, 1921, to September, 1921.
- The Character of Various Fuels for Internal-Combustion Engines. By H. T. Tizard and D. R. Pye. *The Automobile Engineer*, February, 1921, to April, 1921.
- Recent Research Work on the Internal-Combustion Engine. By H. R. Ricardo. *Transactions of the Society of Automotive Engineers*, vol. 17, 1922, part 1, page 1.
- Internal-Combustion-Engine Fuels. By C. A. Norman. *Transactions of the Society of Automotive Engineers*, vol. 17, 1922, part 1, page 141.
- Comparison of Alcogas Aviation Fuel with Export Aviation Gasoline. By V. R. Gage, S. W. Sparrow, and D. R. Harper, 3d. Report 89 of National Advisory Committee for Aeronautics, 1920.
- Comparison of Hecter Fuel with Export Aviation Gasoline. By H. C. Dickinson, V. R. Gage, and S. W. Sparrow. Report 90 of National Advisory Committee for Aeronautics, 1920.
- Researches on Alcohol as a Motor Fuel. By H. B. Dixon. Report of Imperial Motor Transport Council, October, 1920.
- Alcohol as Fuel. By J. L. Chaloner. *The Automobile Engineer*, April, 1920.
- Detonation Characteristics of Blended Motor Fuels. By Thomas Midgley, jr., and T. A. Boyd. *Transactions of Society of Automotive Engineers*, vol. 17, 1922, part 2, page 39.

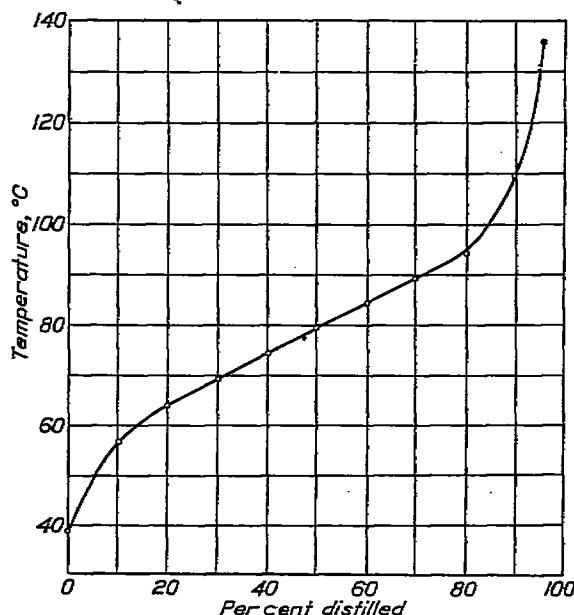

FIG. 13.—Distillation curves of X-gasoline used in alcohol-gasoline solubility tests

- The Problem of Fuel for Aviation Engines. By Prof. Kutzbach. Technical Note No. 62 of National Advisory Committee for Aeronautics, 1921.
- The Problem of Liquid Fuels (for Aircraft Engines). By Prof. Gino Gallo. Technical Memorandum No. 270 of National Advisory Committee for Aeronautics, 1924.
- Fuel for Automotive Apparatus. By E. W. Dean. Transactions of Society of Automotive Engineers, vol. 13, 1918, part 1, page 143.
- The Physical Properties of Motor Fuels. By W. R. Ormandy and E. C. Craven. The Automobile Engineer, March, 1922.
- Spontaneous Ignition Temperatures of Liquid Fuels. By Harold Moore. The Automobile Engineer, May, 1920.
- The Self-Ignition Temperatures of Fuels. By H. T. Tizard. The Automobile Engineer, May, 1923.
- Increase in Maximum Pressures Produced by Preignition in Internal-Combustion Engines. By S. W. Sparrow. Technical Note No. 14 of National Advisory Committee for Aeronautics, 1920.
- Methods of Measuring Detonation in Engines. By Thomas Midgley, jr., and T. A. Boyd. Transactions of Society of Automotive Engineers, vol. 17, 1922, part 1, page 126.
- Comparing Maximum Pressures in Internal-Combustion Engines. By S. W. Sparrow and S. M. Lee. Technical Note No. 101 of National Advisory Committee for Aeronautics, 1922.
- The Background of Detonation. By S. W. Sparrow. Technical Note No. 93 of National Advisory Committee for Aeronautics, 1922.
- Testing Fuels for High-Compression Engines. By S. M. Lee and S. W. Sparrow. Journal of Society of Automotive Engineers, January, 1923.
- The Testing of Motor Fuels. By T. A. Boyd. Automotive Industries, October 13 and 20, 1921.
- The Effect of Changes in Compression Ratio upon Engine Performance. By S. W. Sparrow. Report No. 205 of National Advisory Committee for Aeronautics, 1925.
- The Economical Utilization of Liquid Fuel. By Carl A. Norman. Bulletin No. 19 of Engineering Experiment Station of the Ohio State University, 1921.
- Preignition and Spark Plugs. By S. W. Sparrow. Transactions of Society of Automotive Engineers, vol. 15, 1920, part 1, page 412.
- More Efficient Utilization of Fuel. By C. F. Kettering. Transactions of Society of Automotive Engineers, vol. 14, 1919, part 1, page 201.
- Combustion of Fuels in Internal-Combustion Engines. By C. F. Kettering. Transactions of Society of Automotive Engineers, vol. 15, 1920, part 2, page 453.
- Combustion of Fuels. By Thomas Midgley, jr. Transactions of Society of Automotive Engineers, vol. 15, 1920, part 2, page 659.
- Bureau of Standards Fuel Study. By H. C. Dickinson. Transactions of Society of Automotive Engineers, vol. 16, 1921, part 1, page 111.
- Turbulence. By H. L. Horning. Transactions of Society of Automotive Engineers, vol. 16, 1921, part 2, page 93.
- Elements of Automobile Fuel Economy. By W. S. James. Transactions of Society of Automotive Engineers, vol. 16, 1921, part 2, page 191.
- Condensation Temperatures of Gasoline and Kerosene-Air Mixtures. By Robert E. Wilson and Daniel P. Barnard, 4th. Journal of Society of Automotive Engineers, November, 1921.
- Further Data on the Effective Volatility of Motor Fuels. By Robert E. Wilson and Daniel P. Barnard, 4th. Journal of Society of Automotive Engineers, March, 1923.
- Effect of Doped Fuels on the Fuel System. (From Report of Engineering Div. of Air Service.) Automotive Industries, March 23, 1922.
- Is There Any Available Source of Heat Energy Lighter than Gasoline? By P. Meyer. Technical Note No. 136 of National Advisory Committee for Aeronautics, 1923.
- "Airplane Crashes: Engine Trouble." A Possible Explanation. By S. W. Sparrow. Technical Note No. 55 of National Advisory Committee for Aeronautics, 1921.
- Disturbing Effect of Free Hydrogen on Fuel Combustion in Internal-Combustion Engines. By A. Riedler. Technical Note No. 133 of National Advisory Committee for Aeronautics, 1923.